



SK8552

LINEAR INTEGRATED CIRCUIT

LOW VOLTAGE OPERATION HALL IC

■ DESCRIPTION

SK8552 is a semiconductor integrated circuit utilizing the Hall effect. It has been so designed as to operate in the alternating magnetic field especially at low supply voltage and operation over extended temperature ranges to +125°C. This Hall IC is suitable for application to various kinds of sensors, contact-less switches, and the like.

■ FEATURES

- * Wide supply voltage range of 3V to 20V
- * Wide temperature operation range of -20°C ~ +125°C
- * TTL and MOS IC are directly drivable by the output
- * The life is semipermanent because it employs contactless parts
- * Equipped with an output pull-up resistor (typical 20kΩ)

■ APPLICATION

- * Position sensor
- * Contact-less sensor
- * Detection of cover (open/close)

■ ORDERING INFORMATION

Ordering Number		Package	Pin Assignment					Packing
Lead Free	Halogen Free		1	2	3	4	5	
SK8552L-AF5-R	SK8552G-AF5-R	SOT-25	G	G	O	I	N	Tape Reel
SK8552L-G03-B	SK8552G-G03-B	SIP-3	I	G	O	-	-	Tape Box
SK8552L-G03-K	SK8552G-G03-K	SIP-3	I	G	O	-	-	Bulk

Note: Pin Assignment: I: V_{CC} O: V_{OUT} G: GND N: No Connection

<p>SK8552G-AF5-R</p> <p>(1) Packing Type (2) Package Type (3) Green Package</p>	<p>(1) R: Tape Reel, B: Tape Box, K: Bulk (2) AF5: SOT-25, G03: SIP-3 (3) G: Halogen Free and Lead Free, L: Lead Free</p>
---	---

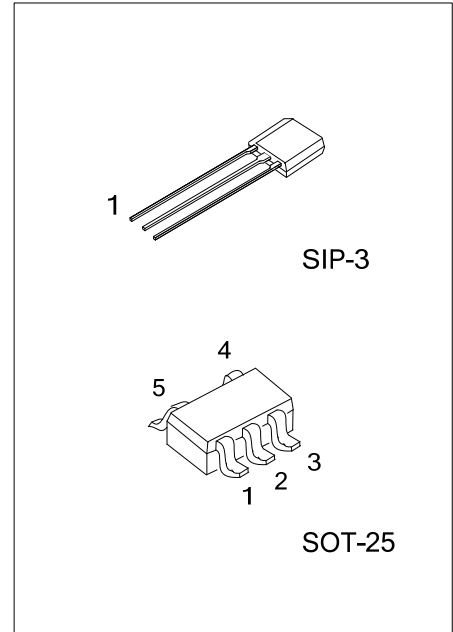

MARKING

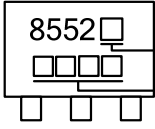
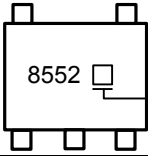
SIP-3	SOT-25
 <p>8552 □ □ □ □ □ □ □ □ □</p> <p>L: Lead Free G: Halogen Free Date Code</p>	 <p>8552 □</p> <p>G: Halogen Free L: Lead Free</p>

BLOCK DIAGRAM

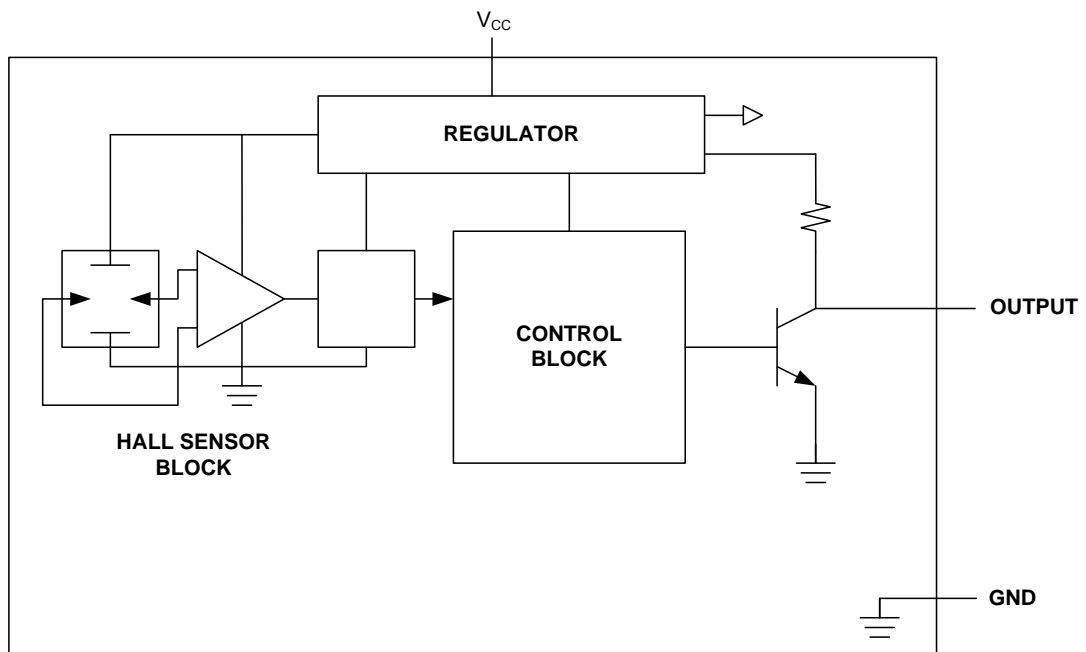

■ ABSOLUTE MAXIMUM RATINGS ($T_A=25^{\circ}\text{C}$, unless otherwise specified)

PARAMETER	SYMBOL	RATINGS	UNIT
Supply Voltage	V_{CC}	3~20	V
Supply Current	I_{CC}	10	mA
Output Current	I_{OUT}	10	mA
Power Dissipation	SIP-3	P_D	400
	SOT-25		200
Junction Temperature	T_J	+125	$^{\circ}\text{C}$
Operating Temperature	T_{OPR}	-20 ~ +125	$^{\circ}\text{C}$
Storage Temperature	T_{STG}	-55 ~ +150	$^{\circ}\text{C}$

Note: Absolute maximum ratings are those values beyond which the device could be permanently damaged. Absolute maximum ratings are stress ratings only and functional device operation is not implied.

■ ELECTRICAL CHARACTERISTICS ($T_A=25^{\circ}\text{C}$, unless otherwise specified)

PARAMETER	SYMBOL	CONDITIONS	MIN	TYP	MAX	UNIT
Output voltage SH	V_{OHS}	$V_{CC}=3\text{V}, I_{OUT}=-10\mu\text{A}, B=100\text{G}$		2.8	3	V
Output voltage NH	V_{OHN}	$V_{CC}=3\text{V}, I_{OUT}=-10\mu\text{A}, B=-100\text{G}$		2.8	3	V
Output voltage SL	V_{OLS}	$V_{CC}=3\text{V}, I_{OUT}=1\text{mA}, B=5\text{G}$			0.7	V
Output voltage NL	V_{OLN}	$V_{CC}=3\text{V}, I_{OUT}=1\text{mA}, B=-5\text{G}$			0.7	V
Output current 1	I_{OHS}	$V_{CC}=3\text{V}, V_{OUT}=3\text{V}, B=100\text{G}$		10		mA
Output current 2	I_{OHN}	$V_{CC}=3\text{V}, V_{OUT}=3\text{V}, B=-100\text{G}$		10		mA
Supply current	I_{CC}	$V_{CC}=3\text{V}, B=5\text{G}$		5		mA
Output switching time	T_R			5		μS
	T_F			1		μS
MAGNETIC CHARACTERISTICS (over operating supply voltage range)						
Operating magnetic flux density	BHLS	$V_{CC}=3\text{V}$	20			G
Operating magnetic flux density	BHLN	$V_{CC}=3\text{V}$	-20			G
Operating magnetic flux density	BLHS	$V_{CC}=3\text{V}$			100	G
Operating magnetic flux density	BLHN	$V_{CC}=3\text{V}$			-100	G

■ PACKAGE INFORMATION

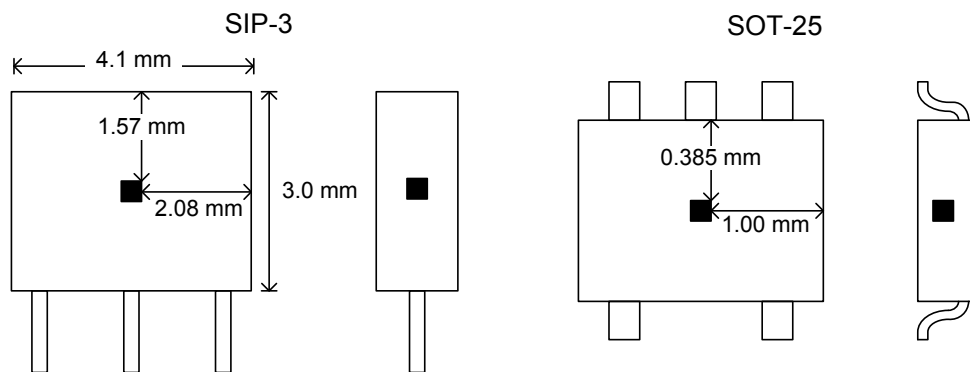

Fig. 1 SENSOR LOCATIONS

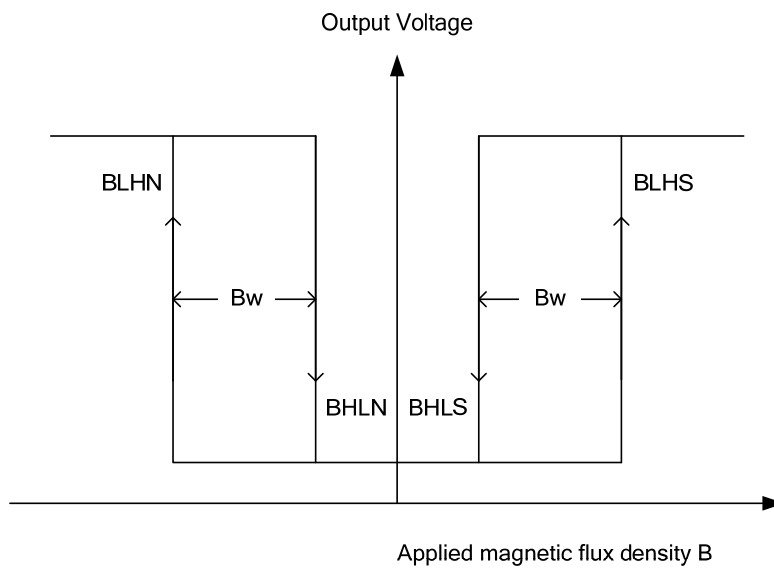
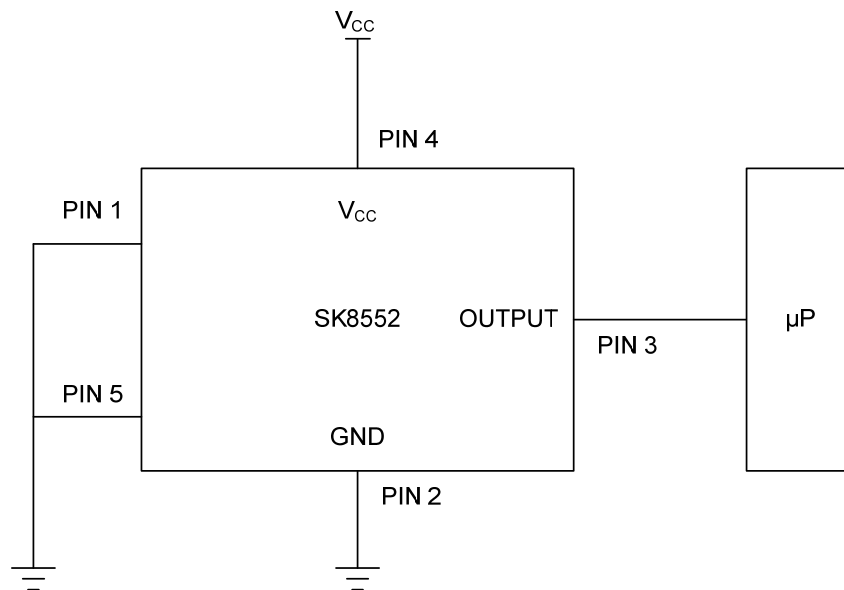

Fig. 2 OPERATING MAGNETIC FLUX DENSITY

■ TYPICAL APPLICATION CIRCUIT



UTC assumes no responsibility for equipment failures that result from using products at values that exceed, even momentarily, rated values (such as maximum ratings, operating condition ranges, or other parameters) listed in products specifications of any and all UTC products described or contained herein. UTC products are not designed for use in life support appliances, devices or systems where malfunction of these products can be reasonably expected to result in personal injury. Reproduction in whole or in part is prohibited without the prior written consent of the copyright owner. UTC reserves the right to make changes to information published in this document, including without limitation specifications and product descriptions, at any time and without notice. This document supersedes and replaces all information supplied prior to the publication hereof.