



LM317M

LINEAR INTEGRATED CIRCUIT

MEDIUM CURRENT 1.2V TO 37V ADJUSTABLE VOLTAGE REGULATOR

■ DESCRIPTION

The UTC **LM317M** is an adjustable 3-terminal positive voltage regulator, designed to supply 500mA of output current with voltage adjustable from 1.2V ~ 37V.

■ FEATURES

- *Output Voltage Adjustable From 1.2V ~ 37V
- *Output Current In Excess of 500mA
- *Internal Thermal Overload Protection
- *Internal Short Circuit Current Limiting
- *Output Transistor Safe Area Compensation

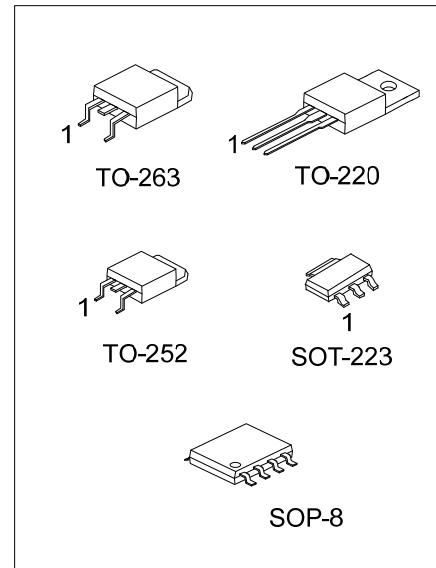

■ ORDERING INFORMATION

Ordering Number		Package	Pin Assignment								Packing	
Lead Free	Halogen Free		1	2	3	4	5	6	7	8		
LM317ML-AA3-R	LM317MG-AA3-R	SOT-223	ADJ	O	I	-	-	-	-	-	-	Tape Reel
LM317ML-TA3-T	LM317MG-TA3-T	TO-220	ADJ	O	I	-	-	-	-	-	-	Tube
LM317ML-TN3-R	LM317MG-TN3-R	TO-252	ADJ	O	I	-	-	-	-	-	-	Tape Reel
LM317ML-TQ2-T	LM317MG-TQ2-T	TO-263	ADJ	O	I	-	-	-	-	-	-	Tube
LM317ML-TQ2-R	LM317MG-TQ2-R	TO-263	ADJ	O	I	-	-	-	-	-	-	Tape Reel
LM317ML-S08-R	LM317MG-S08-R	SOP-8	I	O	O	ADJ	x	O	O	O	x	Tape Reel

Note: Pin Assignment: I: V_{IN} O: V_{OUT} x: NC

<p>LM317MG-AA3-R</p> <p>(1)Packing Type (2)Package Type (3)Green Package</p>	<p>(1) R: Tape Reel, T: Tube (2) AA3: SOT-223, TA3: TO-220, TN3: TO-252, TQ2: TO-263, S08: SOP-8 (3) G: Halogen Free and Lead Free, L: Lead Free</p>
--	--

LM317M

LINEAR INTEGRATED CIRCUIT

MARKING

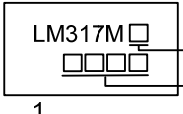
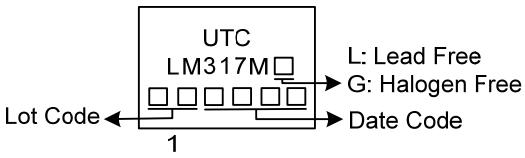
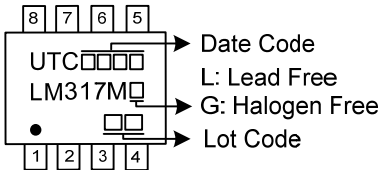
PACKAGE	MARKING
SOT-223	 <p>LM317M</p> <p>→ L: Lead Free → G: Halogen Free → Date Code</p> <p>1</p>
TO-220 TO-252 TO-263	 <p>UTC LM317M</p> <p>→ L: Lead Free → G: Halogen Free → Date Code</p> <p>← Lot Code</p> <p>1</p>
SOP-8	 <p>8 7 6 5</p> <p>UTC LM317M</p> <p>→ Date Code → L: Lead Free → G: Halogen Free → Lot Code</p> <p>1 2 3 4</p>

BLOCK DIAGRAM

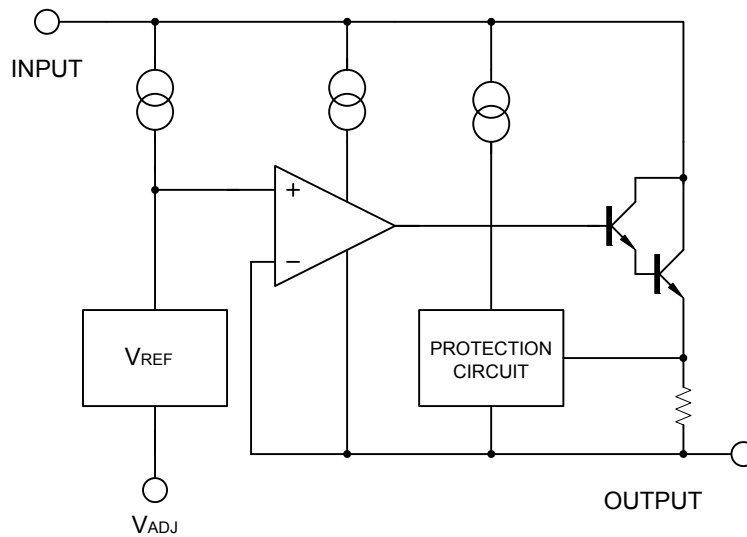

■ ABSOLUTE MAXIMUM RATINGS

PARAMETER	SYMBOL	RATINGS	UNIT
Input-Output Voltage Differential	$V_{IN}-V_{OUT}$	40	V
Power Dissipation	P_D	Internally Limited	W
Junction Temperature	T_J	+150	°C
Operating Temperature	T_{OPR}	-40 ~ +125	°C
Storage Temperature	T_{STG}	-40 ~ +150	°C

Note: Absolute maximum ratings are those values beyond which the device could be permanently damaged.

Absolute maximum ratings are stress ratings only and functional device operation is not implied.

■ THERMAL DATA

PARAMETER	SYMBOL	RATINGS	UNIT	
Junction to Ambient	θ_{JA}	SOT-223	165	°C/W
		SOP-8	175	
		TO-220/TO-263	65	
		TO-252	112	
Junction to Case	θ_{JC}	SOT-223	24	°C/W
		SOP-8	27	
		TO-220/TO-263	5.5	
		TO-252	13	

■ ELECTRICAL CHARACTERISTICS

($V_{IN}-V_{OUT}=5V$, $I_{OUT}=0.1A$, $T_A=25^\circ C$, unless otherwise specified.)

PARAMETER	SYMBOL	TEST CONDITIONS	MIN	TYP	MAX	UNIT	
Line Regulation	$\Delta V_{OUT}/V_{OUT}$	$3V \leq V_{IN}-V_{OUT} \leq 40V$		0.01	0.04	%/V	
Load Regulation	ΔV_{OUT}	$10mA \leq I_{OUT} \leq 0.5A$		$V_{OUT} \leq 5V$	5	25	mV
				$V_{OUT} \geq 5V$	0.1	0.5	%
Adjustable Pin Current	I_{ADJ}			50	100	μA	
Adjustable Pin Current Change	ΔI_{ADJ}	$3V \leq V_{IN}-V_{OUT} \leq 40V$, $10mA \leq I_{OUT} \leq 0.5A$, $P_D < 7.5W$		0.2	5	μA	
Reference Voltage	V_{REF}	$3V \leq V_{IN}-V_{OUT} \leq 40V$, $10mA \leq I_{OUT} \leq 0.5A$, $P_D < 7.5W$	1.20	1.25	1.30	V	
Temperature Stability		$T_{MIN} \leq T_J \leq T_{MAX}$		0.7		%/V _{OUT}	
Minimum Load Current for Regulation	$I_{L(MIN)}$	$V_{IN}-V_{OUT}=40V$		3.5	10	mA	
Maximum Output Current	$I_{O(MAX)}$	$V_{IN}-V_{OUT}=40V$, $P_D \leq 7.5W$	0.1	0.2		A	
RMS Noise vs. % of V_{OUT}	eN	$10Hz \leq f \leq 10KHz$		0.003		%/V _{OUT}	
Ripple Rejection	RR	$V_{OUT}=10V, f=120Hz$		$C_{ADJ}=0$	65	dB	
				$C_{ADJ}=10\mu F$	66		80

Note: C_{ADJ} is connected between Adjust pin and Ground.

APPLICATION CIRCUITS

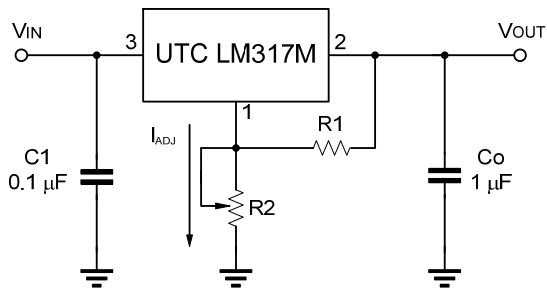

Fig.1 Programmable voltage regulator

$$V_{OUT} = 1.25V * (1 + R2/R1) + I_{ADJ} * R2$$

C1 is required when regulator is located an appreciated distance from power supply. Co is needed to improve transient response.

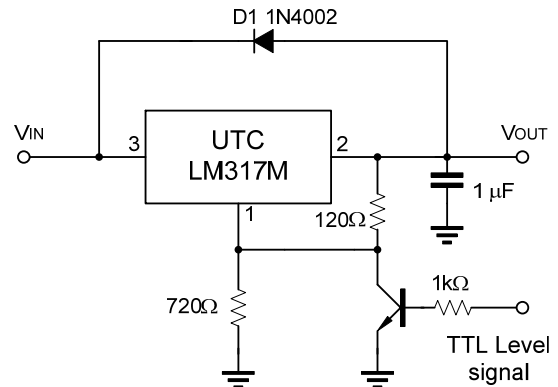

Fig.2 Regulator with On-off control

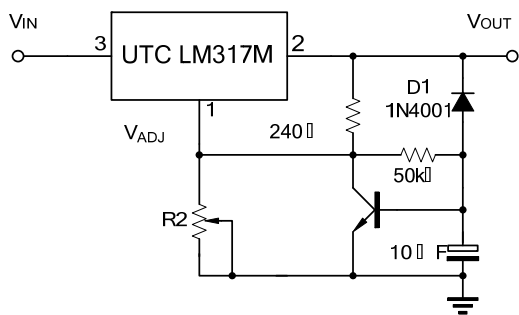
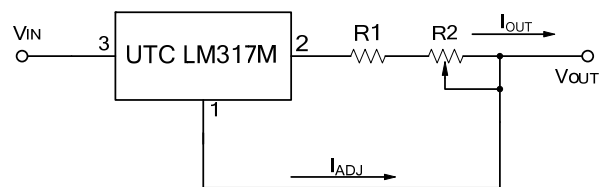

Fig.3 Soft Start Application



$$I_{O(MAX)} = \left(\frac{V_{REF}}{R1} \right) + I_{ADJ} = \frac{1.25V}{R1}$$

$$I_{O(MIN)} = \left(\frac{V_{REF}}{R1 + R2} \right) + I_{ADJ} = \frac{1.25V}{R1 + R2}$$

Fig.4 Constant Current Application

TYPICAL CHARACTERISTICS

Load Regulation vs. temperature

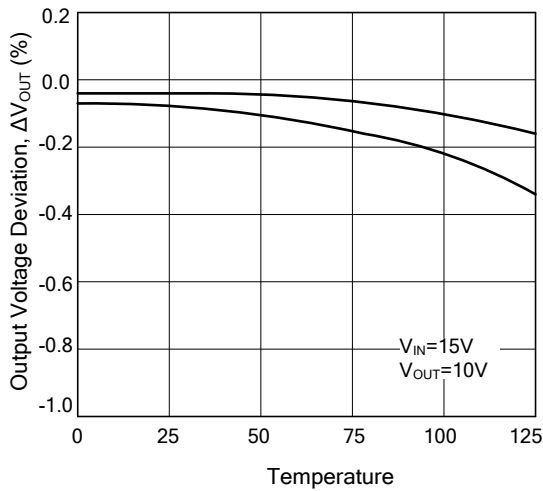

Adjustment Current vs. Temperature

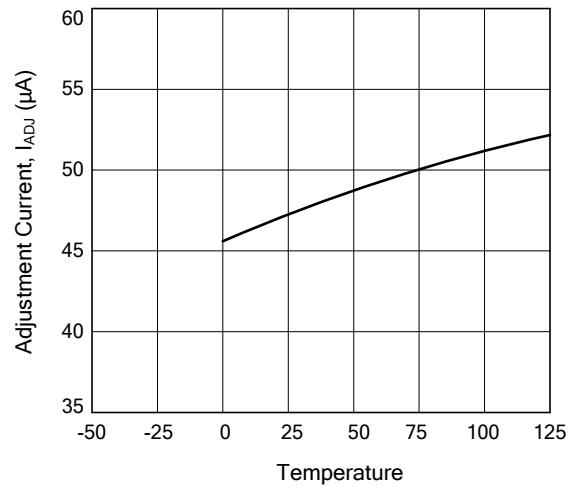

Current Limit

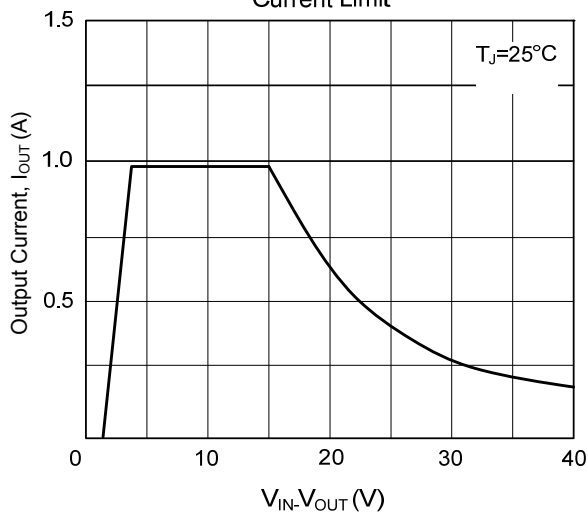

UTC assumes no responsibility for equipment failures that result from using products at values that exceed, even momentarily, rated values (such as maximum ratings, operating condition ranges, or other parameters) listed in products specifications of any and all UTC products described or contained herein. UTC products are not designed for use in life support appliances, devices or systems where malfunction of these products can be reasonably expected to result in personal injury. Reproduction in whole or in part is prohibited without the prior written consent of the copyright owner. UTC reserves the right to make changes to information published in this document, including without limitation specifications and product descriptions, at any time and without notice. This document supersedes and replaces all information supplied prior to the publication hereof.