



LM224

LINEAR INTEGRATED CIRCUIT

QUADRUPLE OPERATIONAL AMPLIFIERS

■ DESCRIPTION

UTC **LM224** consist of four independent, high-gain, frequency-compensated operational amplifiers which are designed to operate from a single power supply over a wide range of voltage. Operation from split supplies is also possible so long as the difference between the two supplies is 3V ~ 32V. The low supply current drain is independent of the magnitude of the supply voltage.

The device can easily be implemented in single supply voltage system, including transducer amplifiers, DC gain blocks, and all of conventional OP Amp circuits.

■ FEATURES

- *Internally frequency compensated for unity gain
- *Large DC voltage gain :100dB
- *Wide operating supply range ($V_{CC}=3V\sim 32V$)
- *Input common-mode voltage includes ground
- *Large output voltage swing: From 0V to $V_{CC}-1.5V$
- *Power drain suitable for battery operation

■ ORDERING INFORMATION

Ordering Number		Package	Packing
Lead Free	Halogen-Free		
LM224L-D14-T	LM224G-D14-T	DIP-14	Tube
LM224L-S14-R	LM224G-S14-R	SOP-14	Tape Reel
LM224L-P14-R	LM224G-P14-R	TSSOP-14	Tape Reel

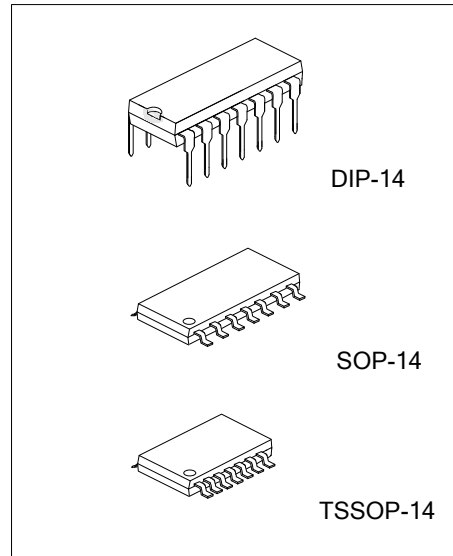

<p>LM224G-D14-T</p> <p>(1)Packing Type (2)Package Type (3)Green Package</p>	<p>(1) T: Tube, R: Tape Reel (2) DIP: DIP-14, S14: SOP-14, P14: TSSOP-14 (3) G: Halogen Free and Lead Free, L: Lead Free</p>
---	--

■ MARKING

DIP-14	SOP-14 / TSSOP-14
<p>UTC □□□□ → Date Code LM224 □ → L: Lead Free □ → G: Halogen Free □□ → Lot Code</p>	<p>UTC □□□□ → Date Code LM224 □ → L: Lead Free □ → G: Halogen Free □□ → Lot Code</p>

■ PIN CONFIGURATION

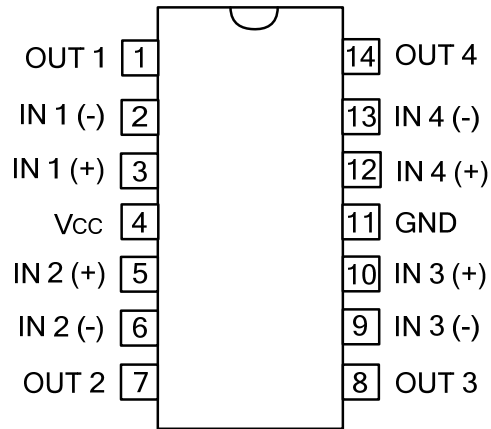

■ ABSOLUTE MAXIMUM RATINGS

PARAMETER	SYMBOL	RATINGS	UNIT
Supply Voltage (Note 1)	V_{CC}	± 16 or 32	V
Differential Input voltage (Note 2)	$V_{I(DIFF)}$	± 32	V
Input Voltage	V_{IN}	-0.3 ~ +32	V
Output Short Circuit (one amplifier) to Ground ($T_A \leq 25^\circ\text{C}$, $V_{CC} \leq 15\text{V}$) (Note 3)		Continuous	
Operation Temperature	T_{OPR}	-40 ~ +105	$^\circ\text{C}$
Storage Temperature	T_{STG}	-65 ~ +150	$^\circ\text{C}$

Notes: 1. All voltage values(except differential voltages and V_{CC} specified for the measurement of $I_{IN(OS)}$) are with respect to the network GND.

2. Differential voltages are at $IN+$ with respect to $IN-$.

3. Short circuits from outputs to V_{CC} can cause excessive heating and eventual destruction.

■ THERMAL DATA

PARAMETER	SYMBOL	RATINGS	UNIT
Thermal Resistance Junction-Ambient	DIP-14	80	$^\circ\text{C/W}$
	SOP-14	86	$^\circ\text{C/W}$
	TSSOP-14	113	$^\circ\text{C/W}$

■ ELECTRICAL CHARACTERISTICS ($V_{CC}=5\text{V}$, unless otherwise specified, $V_{CC}=30\text{V}$ for testing only.)

PARAMETER	SYMBOL	TEST CONDITIONS*	MIN	TYP	MAX	UNIT		
Input Offset Voltage	$V_{I(OFF)}$	$V_{CC}=5\text{V to }30\text{V}$, $V_{IC}=V_{ICR(min)}$, $V_{OUT}=1.4\text{V}$	$T_A=25^\circ\text{C}$		3	5	mV	
			$T_A=-40\sim+105^\circ\text{C}$			7	mV	
Input Offset Current	$I_{I(OFF)}$	$V_{OUT}=1.4\text{V}$	$T_A=25^\circ\text{C}$		2	30	nA	
			$T_A=-40\sim+105^\circ\text{C}$			100	nA	
Input Bias Current	$I_{I(BIAS)}$	$V_{OUT}=1.4\text{V}$	$T_A=25^\circ\text{C}$		-20	-150	nA	
			$T_A=-40\sim+105^\circ\text{C}$			-300	nA	
Input Common-mode Voltage Range	$V_{I(CM)}$	$V_{CC}=5\text{V to }30\text{V}$	$T_A=25^\circ\text{C}$	0		$V_{CC}-1.5$	V	
			$T_A=-40\sim+105^\circ\text{C}$	0		$V_{CC}-2$	V	
Output Voltage Level	High	V_{OH}	$R_L=2\text{k}\Omega$	$T_A=25^\circ\text{C}$	$V_{CC}-1.5$		V	
			$V_{CC}=30\text{V}$, $R_L=2\text{k}\Omega$	$T_A=-40\sim+105^\circ\text{C}$	26			V
			$V_{CC}=30\text{V}$, $R_L \geq 10\text{k}\Omega$		27	28		V
Low	V_{OL}	$R_L \leq 10\text{k}\Omega$	$T_A=-40\sim+105^\circ\text{C}$		5	20	mV	
Large Signal Current Gain	G_v	$V_{CC}=15\text{V}$, $V_{OUT}=1\text{V} \sim 11\text{V}$ $R_L \geq 2\text{k}\Omega$	$T_A=25^\circ\text{C}$	50	100		V/mV	
			$T_A=-40\sim+105^\circ\text{C}$	25			V/mV	
Common-mode Rejection Ratio	CMRR	$V_{IC}=V_{ICR(min)}$	$T_A=25^\circ\text{C}$	70	80		dB	
Supply Voltage Rejection Ratio ($\Delta V_{CC}/\Delta V_{IO}$)	PSRR		$T_A=25^\circ\text{C}$	65	100		dB	
Crosstalk Attenuation	V_{O1}/V_{O2}	$f=1\text{kHz} \sim 20\text{kHz}$	$T_A=25^\circ\text{C}$		120		dB	
Output Current	I_{OUT}	$V_{CC}=15\text{V}$, $V_{ID}=1\text{V}$, $V_{OUT}=0$	$T_A=25^\circ\text{C}$	-20	-30	-60	mA	
			$T_A=-40\sim+105^\circ\text{C}$	-10			mA	
			$T_A=25^\circ\text{C}$	10	20		mA	
			$T_A=-40\sim+105^\circ\text{C}$	5			mA	
Short-circuit Output Current	I_{OS}	$V_{CC}=5\text{V}$, $V_{OUT}=0$, GND at -5V	$T_A=25^\circ\text{C}$		± 40	± 60	mA	
Supply Current (four amplifiers)	I_{CC}	$V_{OUT}=2.5\text{V}$, $R_L=\infty$ $V_{CC}=30\text{V}$, $V_{OUT}=0.5V_{CC}$, $R_L=\infty$	$T_A=-40\sim+105^\circ\text{C}$		0.7	1.2	mA	
					1.4	3	mA	

Note: All characteristics are measured under open-loop conditions with zero common-mode input voltage.

■ SCHEMATIC DIAGRAM (One Section Only)

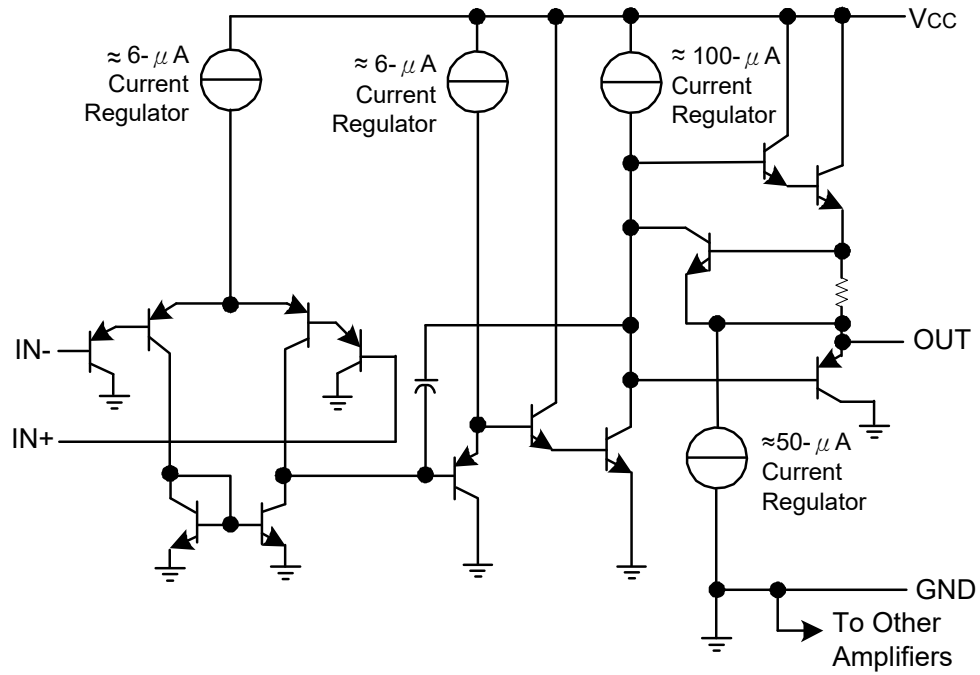

TYPICAL CHARACTERISTICS

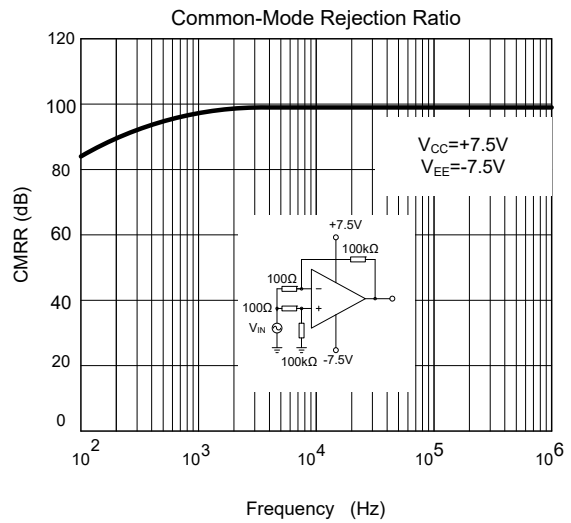
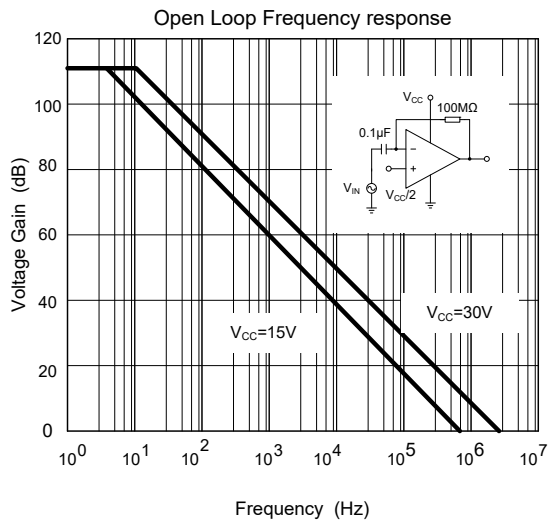
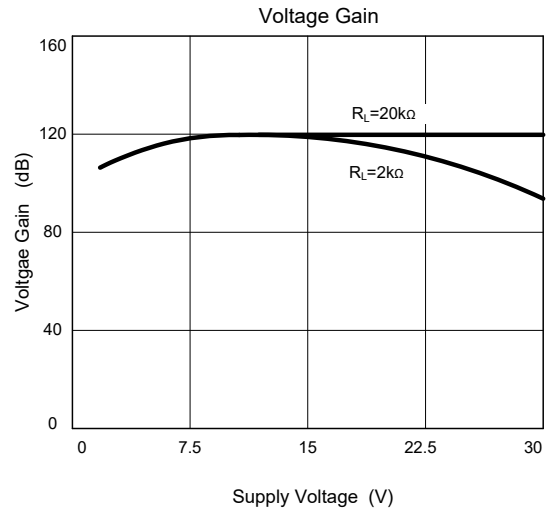
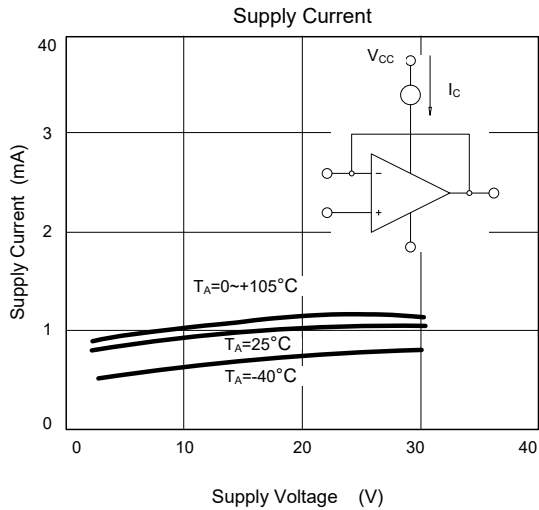
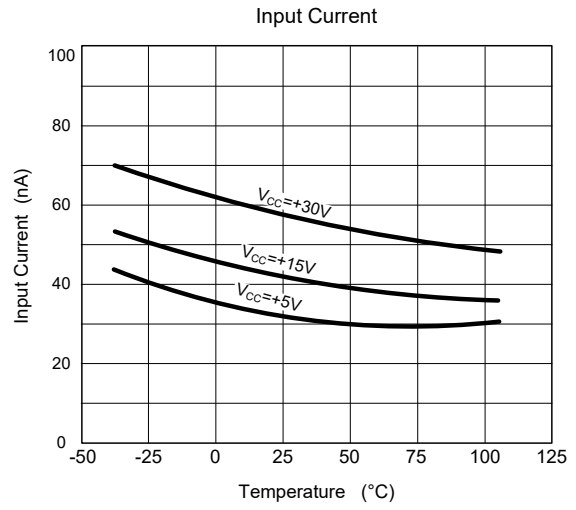
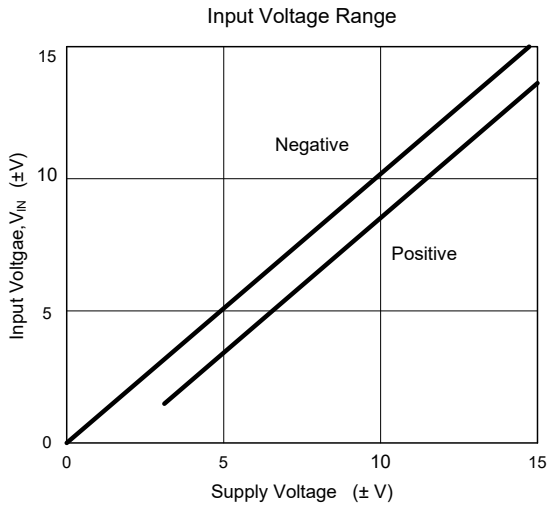

■ TYPICAL CHARACTERISTICS (Cont.)

Voltage Follower Pulse Response

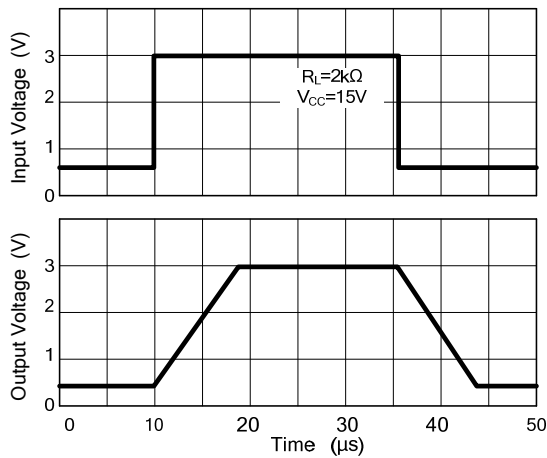

Voltage Follower pulse response (small signal)

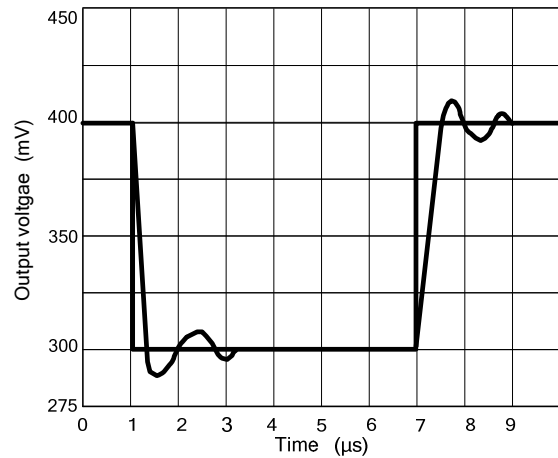

Large Signal Frequency Response

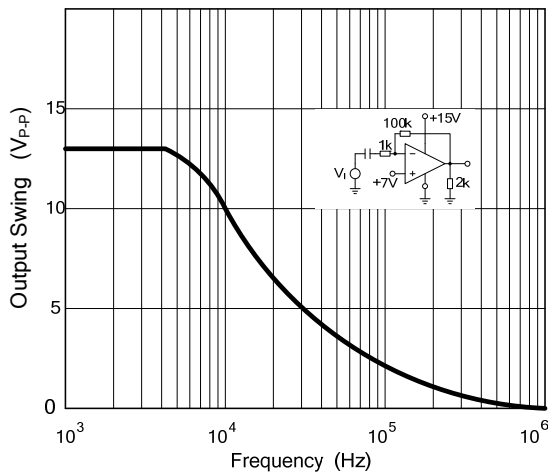

Output Characteristics Current Sourcing

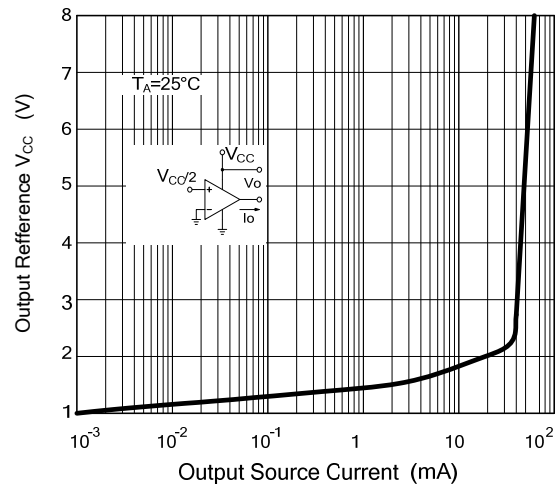

UTC assumes no responsibility for equipment failures that result from using products at values that exceed, even momentarily, rated values (such as maximum ratings, operating condition ranges, or other parameters) listed in products specifications of any and all UTC products described or contained herein. UTC products are not designed for use in life support appliances, devices or systems where malfunction of these products can be reasonably expected to result in personal injury. Reproduction in whole or in part is prohibited without the prior written consent of the copyright owner. UTC reserves the right to make changes to information published in this document, including without limitation specifications and product descriptions, at any time and without notice. This document supersedes and replaces all information supplied prior to the publication hereof.