



M3368

LINEAR INTEGRATED CIRCUIT

3-INPUT VIDEO SWITCH WITH 6dB AMPLIFIER

DESCRIPTION

The UTC **M3368** is three input integrated video switch witch selects one video or audio signal from three input signals.

It contains 6dB amplifier and its operating supply voltage range is 4.75 to 13V and bandwidth is 5MHz.

Crosstalk is 65dB (at 4.43MHz).

FEATURES

- * Operating Voltage: 4.75 ~ 13V
- * 3 Input-1 Output
- * Internal 6dB Amplifier
- * Muting Function available
- * Internal Clamp Function
- * Cross-talk 65dB (at 4.43MHz)
- * Wide Frequency Range 5MHz (1Vp-p Input)

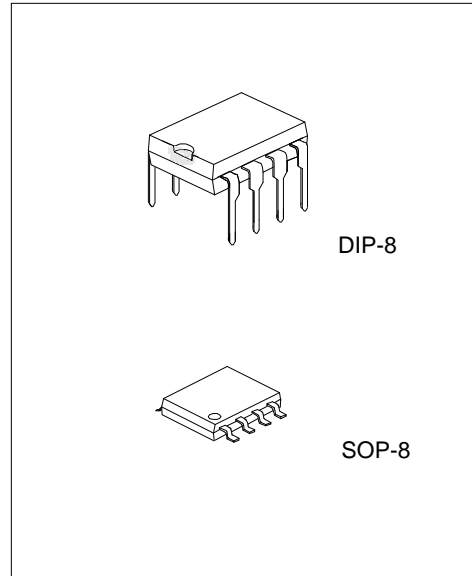

ORDERING INFORMATION

Ordering Number		Package	Packing
Lead Free	Halogen Free		
M3368L-D08-T	M3368G-D08-T	DIP-8	Tube
M3368L-S08-R	M3368G-S08-R	SOP-8	Tape Reel

<p>M3368G-D08-T</p> <ul style="list-style-type: none"> (1) Packing Type (2) Package Type (3) Green Package 	<ul style="list-style-type: none"> (1) T: Tube, R: Tape Reel (2) D08: DIP-8, S08: SOP-8 (3) G: Halogen Free and Lead Free, L: Lead Free
---	--

MARKING

DIP-8	SOP-8
<p>UTC □□□□ M3368 □</p>	<p>UTC □□□□ M3368 □</p>
<p>→ Date Code</p> <p>L: Lead Free</p> <p>G: Halogen Free</p> <p>→ Lot Code</p>	<p>→ Date Code</p> <p>L: Lead Free</p> <p>G: Halogen Free</p> <p>→ Lot Code</p>

■ PIN CONFIGURATION

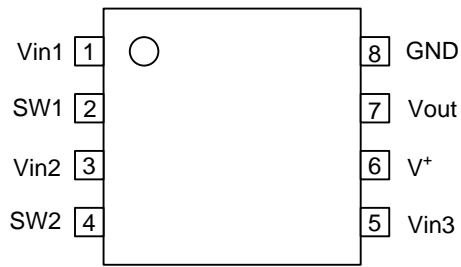

■ BLOCK DIAGRAM

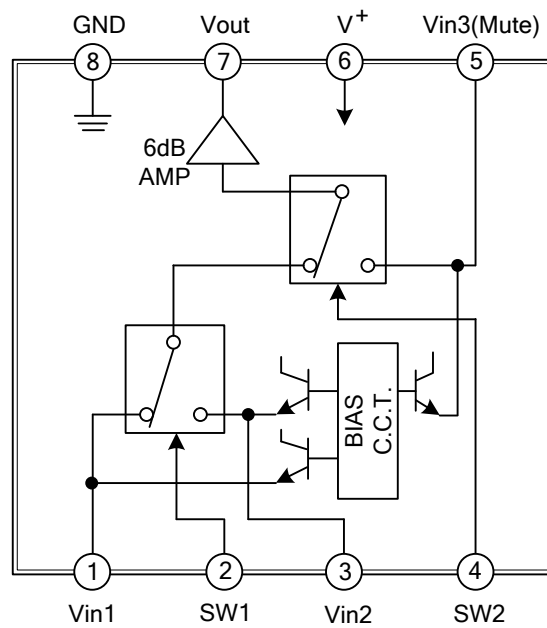

■ PIN DESCRIPTION

PIN NO.	PIN NAME	INSIDE EQUIVALENT CIRCUIT	PIN NO.	PIN NAME	INSIDE EQUIVALENT CIRCUIT
1	VIN1		5	VIN3 (Mute)	
2	SW1		6	V+	
3	VIN2		7	VOUT	
4	SW2		8	GND	

■ INPUT CONTROL SIGNAL-OUTPUT SIGNAL

SW1	SW2	OUTPUT SIGNAL
L	L	Vin 1
H	L	Vin 2
L/H	H	Vin 3

Note: Input clamp voltage is about 2/5 of supply voltage

■ ABSOLUTE MAXIMUM RATING (T_A=25°C)

PARAMETER	SYMBOL	RATINGS	UNIT
Supply Voltage	V ⁺	15	V
Power Dissipation	DIP-8	500	mW
	SOP-8	300	
Operating Temperature	T _{OPR}	-40~+85	°C
Storage Temperature	T _{STG}	-40~+125	°C

Note: Absolute maximum ratings are those values beyond which the device could be permanently damaged. Absolute maximum ratings are stress ratings only and functional device operation is not implied.

■ ELECTRICAL CHARACTERISTICS (V⁺=5V, T_A=25°C)

PARAMETER	SYMBOL	TEST CONDITIONS	MIN	TYP	MAX	UNIT
Recommended Supply Voltage	V ⁺		4.75		13.0	V
Operating Current	I _{CC}	S1=S2=S3=S4=S5=2	9.5	14.0	21.0	mA
Voltage Gain	G _v	V _{in} =1.0V _{p-p} , 1MHz, V _o /V _i , R _L =1kΩ	5.5	6.0	6.5	dB
Frequency Characteristic	G _f	V _{in} =1.0V _{p-p} , V _o (10MHz)/V _o (1MHz), R _L =1kΩ	-1.0		+1.0	dB
Differential Gain	DG	V _{in} =1.0V _{p-p} , staircase, R _L =1kΩ		0.3		%
Differential Phase	DP	V _{in} =1.0V _{p-p} , staircase, R _L =1kΩ		0.3		deg.
Output Offset Voltage	V _{off}	S1=S2=S3=2, S5=1→2, V _o : voltage change			±60	mV
Crosstalk	CT	V _{in} =1V _{p-p} , 4.43MHz, V _o /V _i		-65		dB
Switch Change Voltage	V _{CH}	All inside SW: ON	2.4			V
	V _{CL}	All inside SW: OFF			0.8	

Note: Unless specified, tested with three mode below.

(a) S1=1, S2=S3=S4=S5=2 (b) S2=S4=1, S1=S3=S5=2 (c) S1=S2=2, S3=S5=1, S4=1 or 2

■ APPLICATION

Oscillation Prevention on light loading conditions Recommended under circuit.

This IC requires 1MΩ resistance between INPUT and GND pin for clamp type input since the minute current causes an unstable pin voltage.

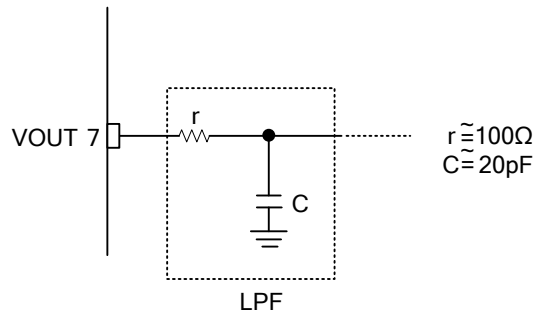

This IC requires 1MΩ resistance between INPUT and GND pin for clamp type input since the minute current causes an unstable pin voltage.

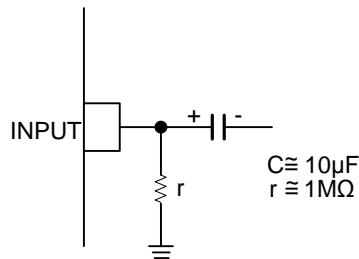

This IC requires 0.1μF capacitor between INPUT and GND, 1MΩ resistance between INPUT and GND for clamp type input at mute mode.

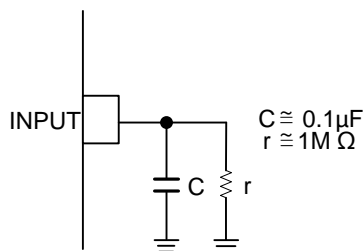

TEST CIRCUIT

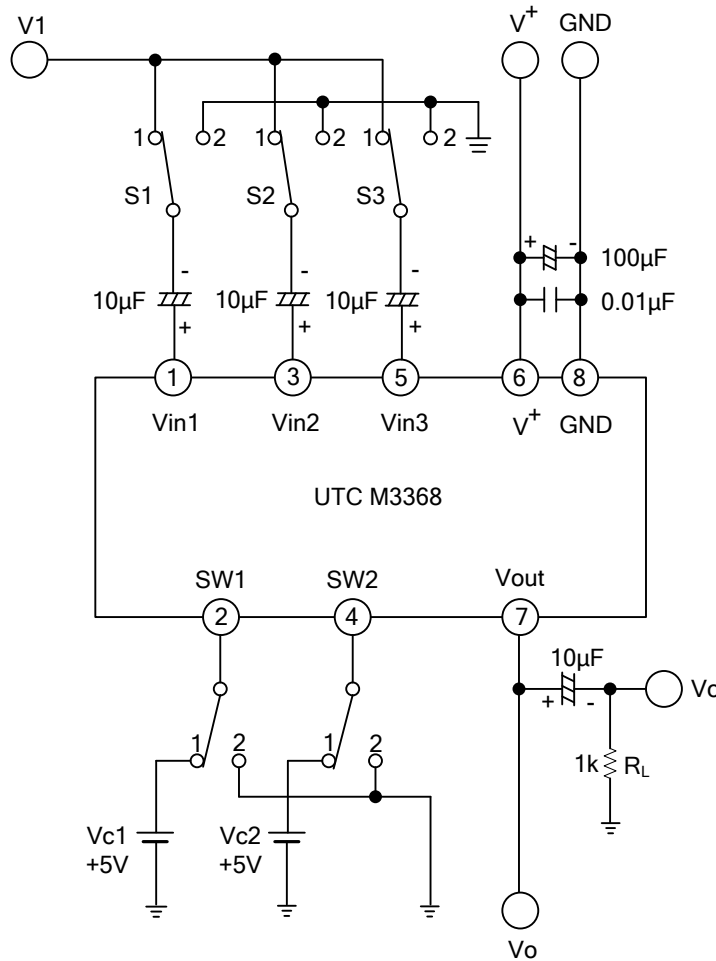

DC VOLTAGE EACH TERMINAL (Typ. on Test Circuit $T_A=25^\circ\text{C}$)

Terminal Name	VIN1	SW1	VIN2	SW2	VIN3	V ⁺	VOUT	GND
DC Voltage	$\frac{2}{5}V^+$		$\frac{2}{5}V^+$		$\frac{2}{5}V^+$		$\frac{2}{5}V^+ - 0.7$	

UTC assumes no responsibility for equipment failures that result from using products at values that exceed, even momentarily, rated values (such as maximum ratings, operating condition ranges, or other parameters) listed in products specifications of any and all UTC products described or contained herein. UTC products are not designed for use in life support appliances, devices or systems where malfunction of these products can be reasonably expected to result in personal injury. Reproduction in whole or in part is prohibited without the prior written consent of the copyright owner. UTC reserves the right to make changes to information published in this document, including without limitation specifications and product descriptions, at any time and without notice. This document supersedes and replaces all information supplied prior to the publication hereof.