



U74HC4051

CMOS IC

8-CHANNEL ANALOG MULTIPLEXER/ DEMULTIPLEXER

DESCRIPTION

The UTC **U74HC4051** is a high-performance, 8-channel analog multiplexer/de-multiplexer.

FEATURES

- * Wide analog input voltage range from -5V to +5V
- * Low ON-state resistance
- * Logic level translation: to enable 5V logic to communicate with $\pm 5V$ analog signals
- * Typical "break before make" built in

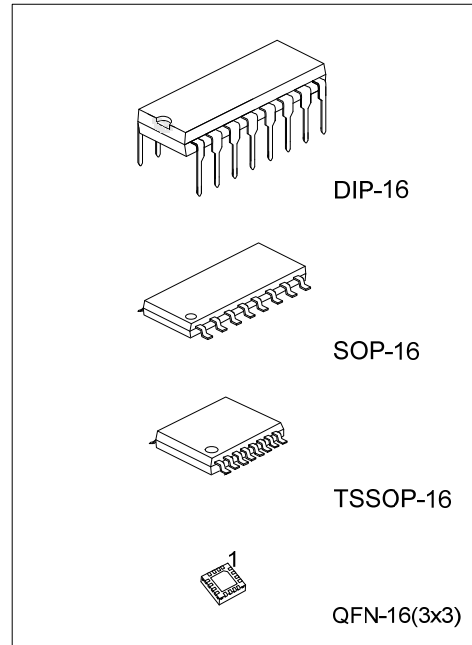

ORDERING INFORMATION

Ordering Number		Package	Packing
Lead Free	Halogen Free		
U74HC4051L-D16-T	U74HC4051G-D16-T	DIP-16	Tube
U74HC4051L-S16-T	U74HC4051G-S16-T	SOP-16	Tube
U74HC4051L-S16-R	U74HC4051G-S16-R	SOP-16	Tape Reel
U74HC4051L-P16-T	U74HC4051G-P16-T	TSSOP-16	Tube
U74HC4051L-P16-R	U74HC4051G-P16-R	TSSOP-16	Tape Reel
U74HC4051L-Q16-3030-R	U74HC4051G-Q16-3030-R	QFN-16(3x3)	Tape Reel

<p>U74HC4051G-D16-T</p> <p>(1) Packing Type</p> <p>(2) Package Type</p> <p>(3) Green Package</p>	<p>(1) T: Tube, R: Tape Reel</p> <p>(2) D16: DIP-16, S16: SOP-16, P16: TSSOP-16 Q16-3030: QFN-16(3x3)</p> <p>(3) G: Halogen Free and Lead Free, L: Lead Free</p>
--	--

MARKING

PACKAGE	MARKING
DIP-16	<p>Date Code L: Lead Free G: Halogen Free Lot Code</p>
SOP-16 TSSOP-16	<p>Date Code L: Lead Free G: Halogen Free Lot Code</p>
QFN-16(3x3)	<p>L: Lead Free G: Halogen Free Date Code</p>

PIN CONFIGURATION

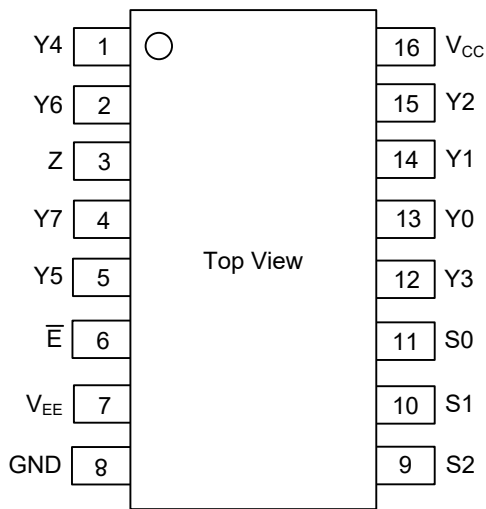

DIP-16/SOP-16/TSSOP-16

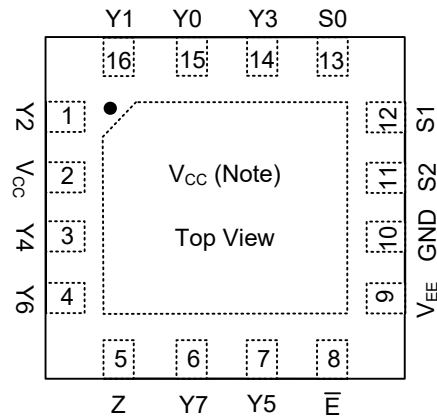

Note: Thermal pad.

QFN-16(3x3)

FUNCTION TABLE

INPUT(\bar{E})	INPUT(S2)	INPUT(S1)	INPUT(S0)	CHANNEL ON
L	L	L	L	Y0 to Z
L	L	L	H	Y1 to Z
L	L	H	L	Y2 to Z
L	L	H	H	Y3 to Z
L	H	L	L	Y4 to Z
L	H	L	H	Y5 to Z
L	H	H	L	Y6 to Z
L	H	H	H	Y7 to Z
H	X	X	X	none

Note: H=High voltage level; L=Low voltage level; X=don't care

■ SCHEMATIC DIAGRAM (one switch)

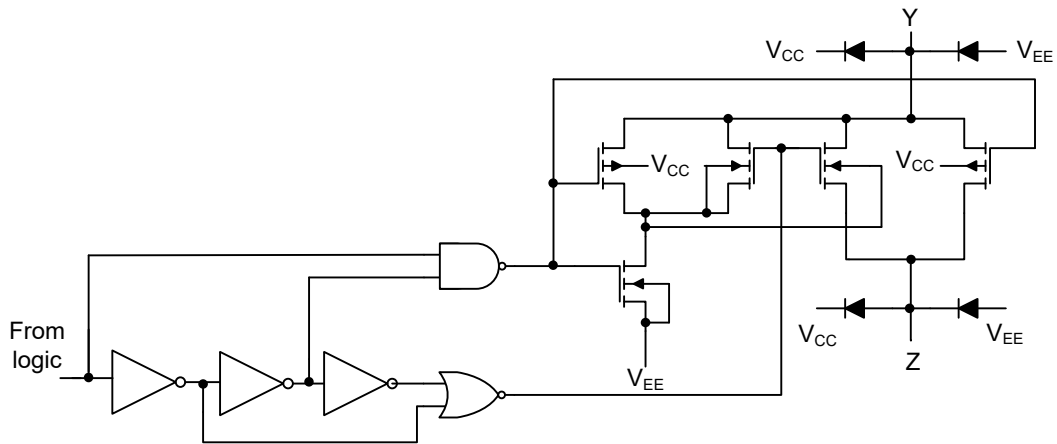

■ FUNCTION DIAGRAM

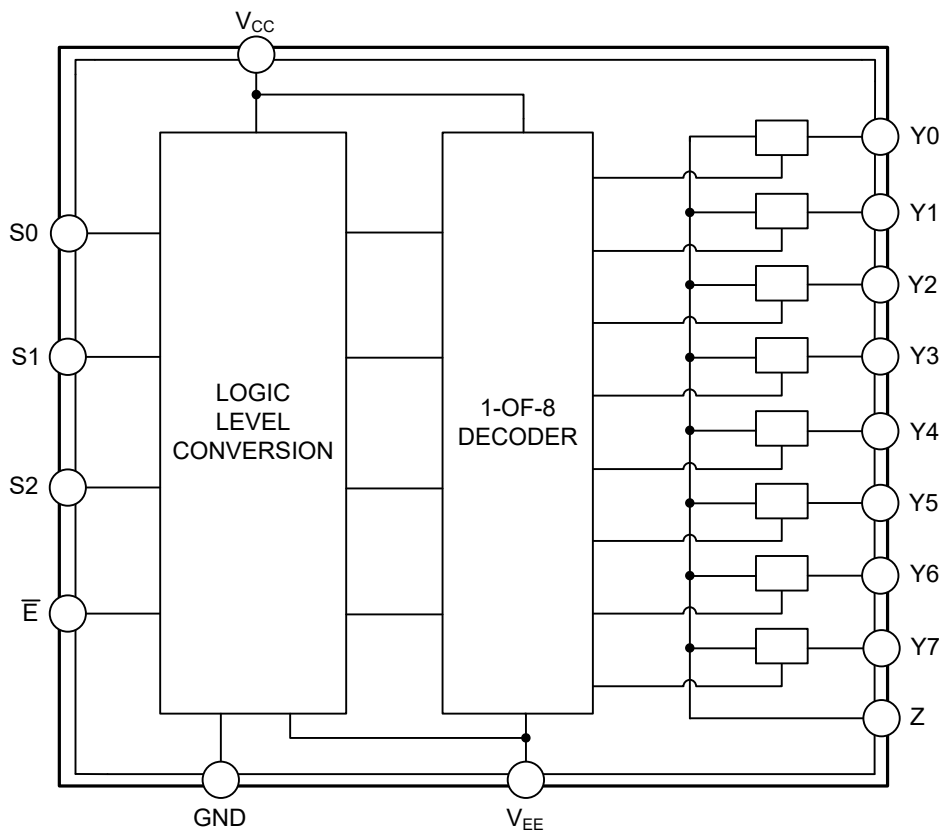

■ ABSOLUTE MAXIMUM RATINGS

PARAMETER		SYMBOL	RATINGS	UNIT
Supply Voltage		V_{CC}	-0.5 ~ +11.0	V
Input Clamping Current ($V_I < -0.5V$ or $V_I > V_{CC} + 0.5V$)		I_{IK}	±20	mA
Switch Clamping Current ($V_S < -0.5V$ or $V_S > V_{CC} + 0.5V$)		I_{SK}	±20	mA
Switch Current ($V_S = -0.5V$ to $V_{CC} + 0.5V$)		I_S	±25	mA
Negative Supply Current		I_{EE}	-20	mA
Ground Supply Current		I_{GND}	-50	mA
Quiescent Supply Current		I_{CC}	50	mA
Power Dissipation	DIP-16	P_D	750	mW
	SOP-16		500	mW
	TSSOP-16		450	mW
	QFN-16(3×3)		1000	mW
Operating Temperature		T_{OPR}	-40 ~ +125	°C
Storage Temperature		T_{STG}	-65 ~ +150	°C

Note: Absolute maximum ratings are those values beyond which the device could be permanently damaged.

Absolute maximum ratings are stress ratings only and functional device operation is not implied.

■ RECOMMENDED OPERATING CONDITIONS

PARAMETER	SYMBOL	CONDITIONS	MIN	TYP	MAX	UNIT
Supply Voltage Difference	ΔV_{CC}	$V_{CC}-GND$	2.0	5.0	10.0	V
		$V_{CC}-V_{EE}$	2.0	5.0	10.0	v
Input Voltage	V_{IN}		GND		V_{CC}	V
Switch Voltage	V_{SW}		V_{EE}		V_{CC}	V
Input Rise and Fall Times	t_R, t_F	$V_{CC}=2.0V$	0		1000	ns
		$V_{CC}=4.5V$	0		500	ns
		$V_{CC}=6.0V$	0		400	ns
		$V_{CC}=10.0V$	0		250	ns

■ STATIC CHARACTERISTICS ($T_A=25^\circ C$, unless otherwise specified)

PARAMETER	SYMBOL	TEST CONDITIONS	MIN	TYP	MAX	UNIT
High-Level Input Voltage	V_{IH}	$V_{CC}=2.0V$	1.5			V
		$V_{CC}=4.5V$	3.15			V
		$V_{CC}=6.0V$	4.2			V
		$V_{CC}=9.0V$	6.3			V
Low-Level Input Voltage	V_{IL}	$V_{CC}=2.0V$			0.5	V
		$V_{CC}=4.5V$			1.35	V
		$V_{CC}=6.0V$			1.8	V
		$V_{CC}=9.0V$			2.7	V
Analog Switch OFF-state Current	$I_{S(OFF)}$	$V_{CC}=10V, V_{EE}=0V, V_I=V_{IH}$ or V_{IL} $ V_S =V_{CC}-V_{EE}$			±0.1	µA
		Per Channel All Channels			±0.4	µA
Analog Switch ON-state Current	$I_{S(ON)}$	$V_{CC}=10V, V_{EE}=0V, V_I=V_{IH}$ or V_{IL} $ V_S =V_{CC}-V_{EE}$			±0.4	µA
Input Leakage Current	$I_{I(LEAK)}$	$V_{EE}=0V$ $V_I=V_{CC}$ or GND	$V_{CC}=6V$		±0.1	µA
			$V_{CC}=10V$		±0.2	µA
Quiescent Supply Current	I_Q	$V_I=V_{CC}$ or GND $V_{IS}=V_{EE}$ or V_{CC} $V_{OS}=V_{CC}$ or V_{EE}	$V_{CC}=6V, V_{EE}=0V$		8	µA
			$V_{CC}=10V, V_{EE}=0V$		16	µA

■ STATIC CHARACTERISTICS (Cont.)

PARAMETER	SYMBOL	TEST CONDITIONS		MIN	TYP	MAX	UNIT	
Input Capacitance	C_i				3.5		pF	
ON-state Resistance	PEAK	$R_{ON(PEAK)}$	$V_{IS}=V_{CC}$ to V_{EE} $V_{IN}=V_{IH}$ or V_{IL}	$V_{EE}=0V, I_S=0.1mA$ (Note)	$V_{CC}=2.0V$		Ω	
				$V_{EE}=0V, I_S=1mA$	$V_{CC}=4.5V$	100	180	Ω
				$V_{EE}=0V, I_S=1mA$	$V_{CC}=6.0V$	90	160	Ω
				$V_{EE}=-4.5V, I_S=1mA$	$V_{CC}=4.5V$	70	130	Ω
				$V_{EE}=0V, I_S=0.1mA$ (Note)	$V_{CC}=2.0V$	150		Ω
				$V_{EE}=0V, I_S=1mA$	$V_{CC}=4.5V$	80	140	Ω
	RAIL	$R_{ON(RAIL)}$	$V_{IS}=V_{EE}$ $V_{IN}=V_{IH}$ or V_{IL}	$V_{EE}=0V, I_S=1mA$	$V_{CC}=6.0V$	70	120	Ω
				$V_{EE}=-4.5V, I_S=1mA$	$V_{CC}=4.5V$	60	105	Ω
				$V_{EE}=0V, I_S=0.1mA$ (Note)	$V_{CC}=2.0V$	150		Ω
				$V_{EE}=0V, I_S=1mA$	$V_{CC}=4.5V$	90	160	Ω
				$V_{EE}=0V, I_S=1mA$	$V_{CC}=6.0V$	80	140	Ω
				$V_{EE}=-4.5V, I_S=1mA$	$V_{CC}=4.5V$	65	120	Ω
Maximum ON-state Resistance Variation Between Any Two Channels	$\Delta R_{ON(MAX)}$	$V_{IS}=V_{CC}$ to V_{EE} $V_{IN}=V_{IH}$ or V_{IL}	$V_{EE}=0V, I_S=0.1mA$ (Note)	$V_{CC}=2.0V$			Ω	
			$V_{EE}=0V, I_S=1mA$	$V_{CC}=4.5V$	9		Ω	
			$V_{EE}=0V, I_S=1mA$	$V_{CC}=6.0V$	8		Ω	
			$V_{EE}=-4.5V, I_S=1mA$	$V_{CC}=4.5V$	6		Ω	

Note: At supply voltages ($V_{CC} - V_{EE}$) approaching 2.0 V the analog switch ON-resistance becomes extremely non-linear. Therefore it is recommended that these devices be used to transmit digital signals only, when using these supply voltages.

■ DYNAMIC CHARACTERISTICS (GND=0V, $t_r=t_f=6ns$, $T_A=25^\circ C$, unless otherwise specified)

PARAMETER	SYMBOL	TEST CONDITIONS		MIN	TYP	MAX	UNIT	
Minimum Frequency Response (-3dB)	f_{max}	$R_L=50\Omega, C_L=50pF$	$V_{EE}=-2.25V$	$V_{CC}=2.25V$		130	MHz	
			$V_{EE}=-4.5V$	$V_{CC}=4.5V$		180	MHz	
Propagation Delay Form V_{IS} to V_{OS}	t_{PHL}/t_{PLH}	$R_L=\infty, C_L=50pF$	$V_{EE}=0V$	$V_{CC}=2.0V$		14	60	ns
				$V_{CC}=4.5V$		5	12	ns
			$V_{EE}=-4.5V$	$V_{CC}=6.0V$		4	10	ns
				$V_{CC}=4.5V$		4	8	ns
Turn-ON Time	\bar{E} to V_{OS}	$R_L=1k\Omega, C_L=50pF$	$V_{EE}=0V$	$V_{CC}=2.0V$		72	345	ns
				$V_{CC}=4.5V$		29	69	ns
			$V_{EE}=-4.5V$	$V_{CC}=6.0V$		21	59	ns
				$V_{CC}=4.5V$		18	51	ns
	S_n to V_{OS}	$R_L=1k\Omega, C_L=15pF$	$V_{EE}=0V$	$V_{CC}=5.0V$		22		ns
				$V_{CC}=2.0V$		66	345	ns
			$V_{EE}=0V$	$V_{CC}=4.5V$		28	69	ns
				$V_{CC}=6.0V$		19	59	ns
Turn-OFF Time	\bar{E} to V_{OS}	$R_L=1k\Omega, C_L=50pF$	$V_{EE}=0V$	$V_{CC}=2.0V$		58	290	ns
				$V_{CC}=4.5V$		31	58	ns
			$V_{EE}=-4.5V$	$V_{CC}=6.0V$		17	49	ns
				$V_{CC}=4.5V$		18	42	ns
	S_n to V_{OS}	$R_L=1k\Omega, C_L=15pF$	$V_{EE}=0V$	$V_{CC}=5.0V$		18		ns
				$V_{CC}=2.0V$		61	290	ns
			$V_{EE}=0V$	$V_{CC}=4.5V$		25	58	ns
				$V_{CC}=6.0V$		18	49	ns
$V_{EE}=-4.5V$	$V_{CC}=4.5V$		18	42	ns			
	$V_{CC}=5.0V$		19		ns			

Note: V_{IS} is the input voltage at a Yn or Z terminal, whichever is assigned as an input.

V_{OS} is the output voltage at a Yn or Z terminal, whichever is assigned as an output.

■ TEST CIRCUITS AND WAVEFORMS

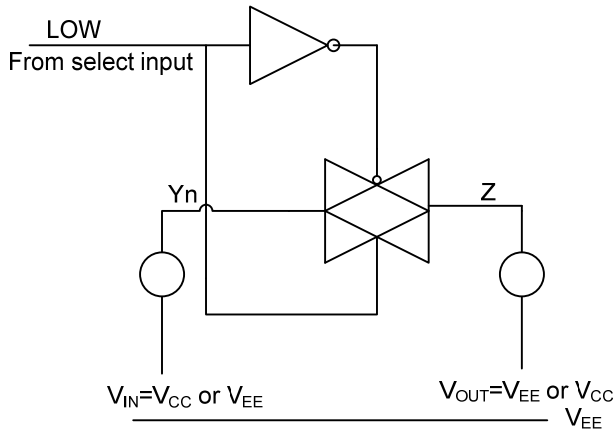

Figure 1. OFF-state current

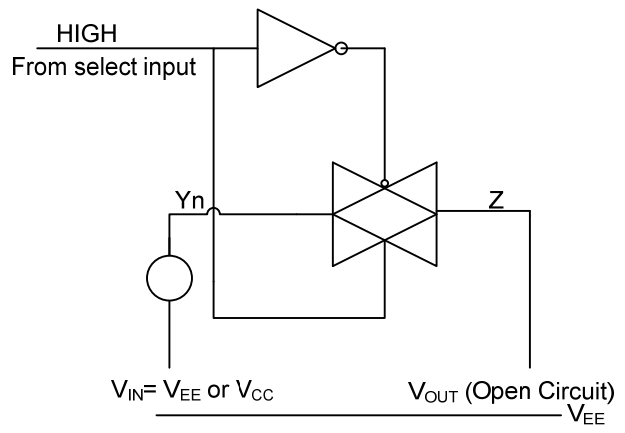

Figure 2. ON-state current

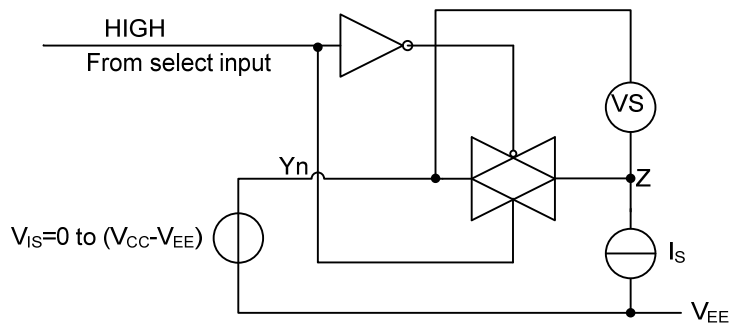

Figure 3. R_{ON}

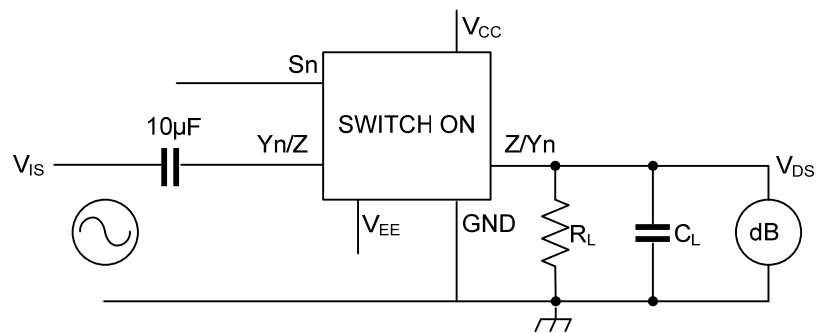

Figure 4. Frequency Response

■ TEST CIRCUITS AND WAVEFORMS (Cont.)

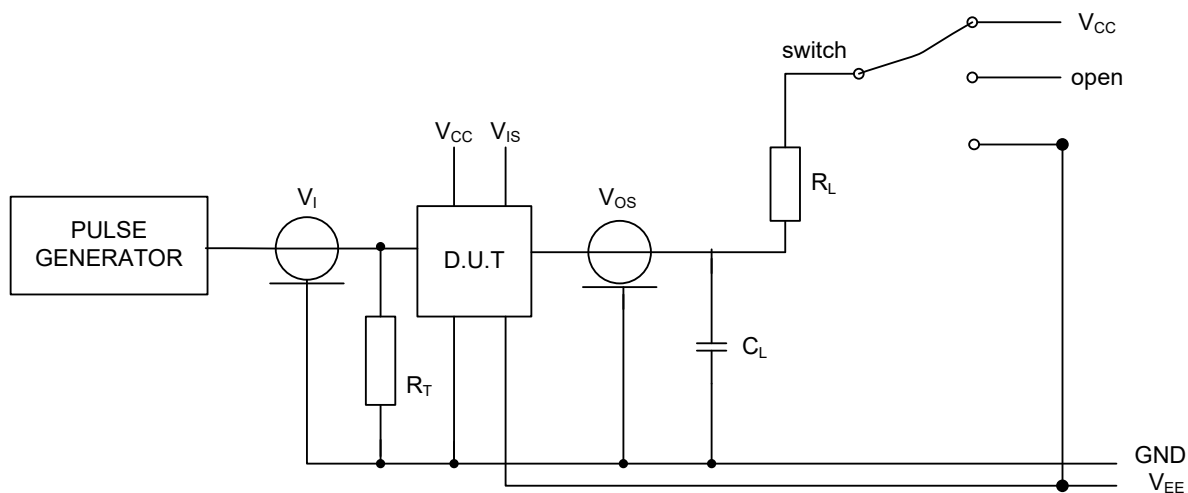

Figure. 5. AC performance

TEST	SWITCH	INPUT	
		V_{IS}	t_R, t_F
t_{PZH}	V_{EE}	V_{CC}	6ns
t_{PZL}	V_{CC}	V_{EE}	6ns
t_{PHZ}	V_{EE}	V_{CC}	6ns
t_{PLZ}	V_{CC}	V_{EE}	6ns
t_{PLH}	Open	Pulse	6ns
t_{PHL}	Open	Pulse	6ns

Notes: 1. Definitions for test circuit:

R_L = load resistance

C_L = load capacitance including jig and probe capacitance.

R_T = termination resistance should be equal to the output impedance Z_O of the pulse generator.

2. $t_R=t_F=6$ ns; when measuring f_{MAX} , there is no constraint to t_r and t_f with 50% duty factor (< 2ns).

■ TEST CIRCUITS AND WAVEFORMS(Cont.)

The Input (V_{IS}) to Output (V_{OS}) propagation delays Waveform

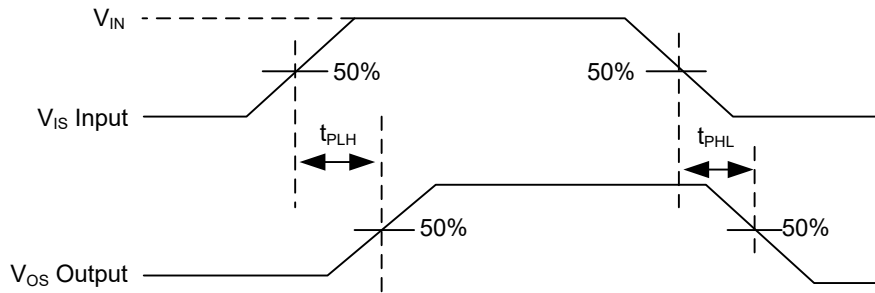

The turn-on and turn-off times Waveform

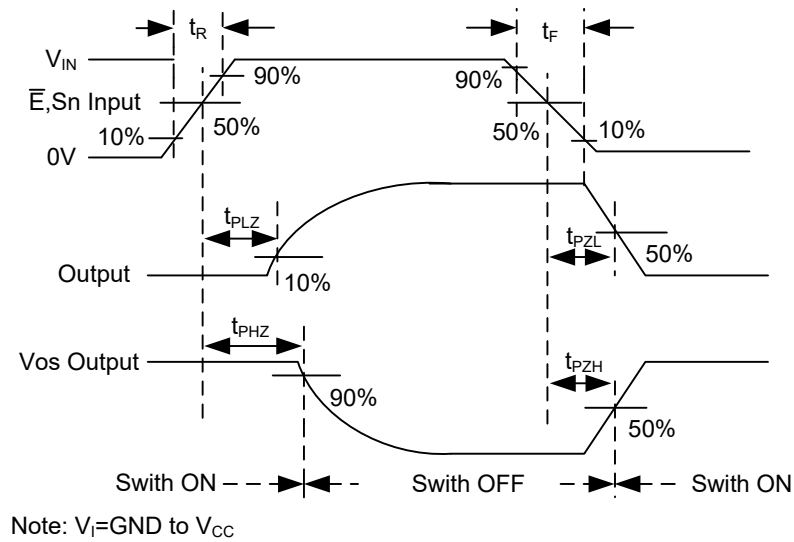

Input pulse definition

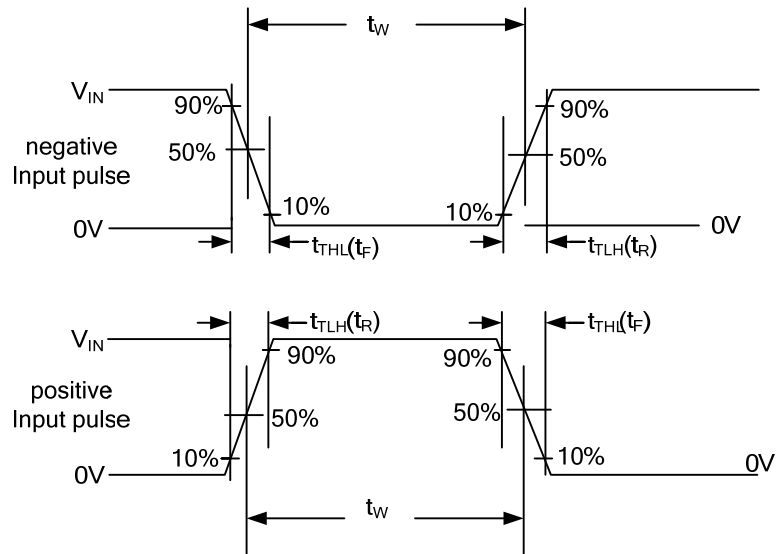

■ TYPICAL CHARACTERISTICS

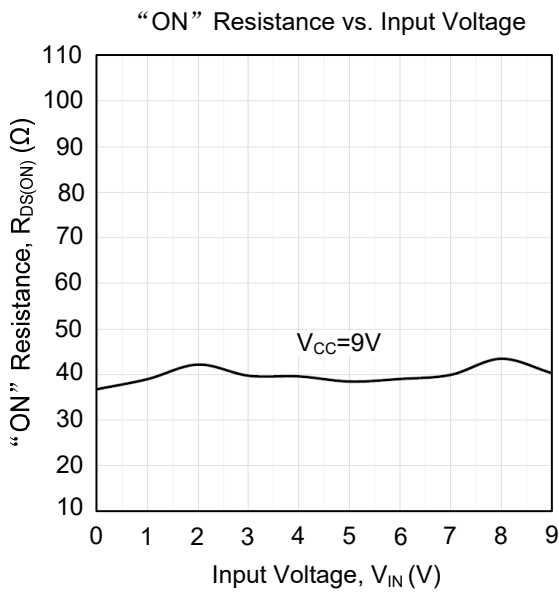
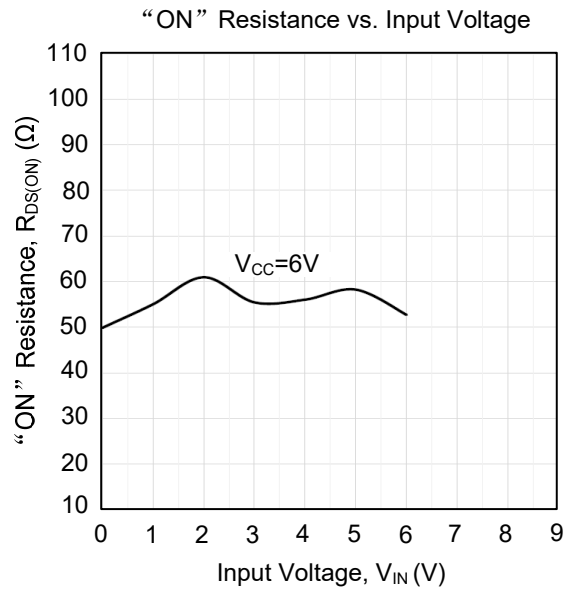
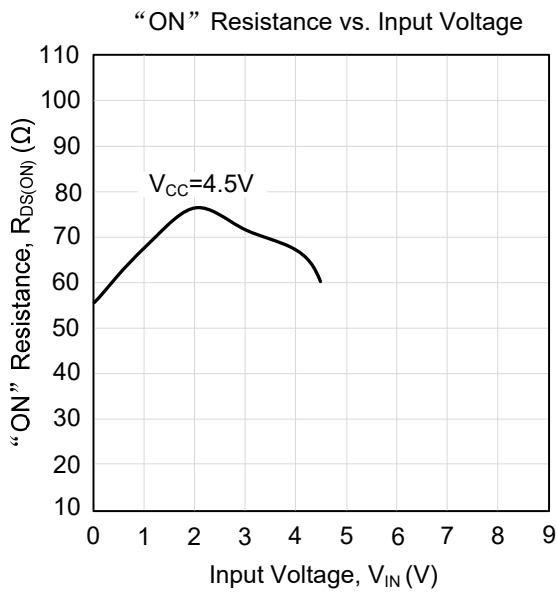

UTC assumes no responsibility for equipment failures that result from using products at values that exceed, even momentarily, rated values (such as maximum ratings, operating condition ranges, or other parameters) listed in products specifications of any and all UTC products described or contained herein. UTC products are not designed for use in life support appliances, devices or systems where malfunction of these products can be reasonably expected to result in personal injury. Reproduction in whole or in part is prohibited without the prior written consent of the copyright owner. UTC reserves the right to make changes to information published in this document, including without limitation specifications and product descriptions, at any time and without notice. This document supersedes and replaces all information supplied prior to the publication hereof.