



# U74LVC1G3157

**CMOS IC**

## SINGLE-POLE, DOUBLE-THROW ANALOG SWITCH

### DESCRIPTION

The UTC **U74LVC1G3157** is a low voltage single-pole, double-throw (SPDT) analog switch intending for use in chopping, modem, signal gating, and signal multiplexing for analog-to-digital and digital-to-analog conversion systems.

### FEATURES

- \* Useful in Both Analog and Digital Applications
- \* Rail-to-Rail Signal Handing
- \* Low ON Resistance: < 10Ω on Typical @ 3.3V V<sub>CC</sub>
- \* Broad V<sub>CC</sub> Operating Range: 1.65V to 5.5V
- \* Over-Voltage Tolerance of Control Input to 6.5V

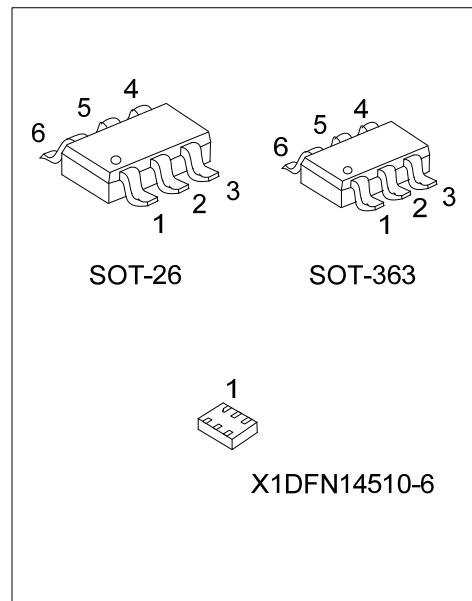

### ORDERING INFORMATION

Ordering Number		Package	Packing
Lead Free	Halogen Free		
U74LVC1G3157L-AG6-R	U74LVC1G3157G-AG6-R	SOT-26	Tape Reel
U74LVC1G3157L-AL6-R	U74LVC1G3157G-AL6-R	SOT-363	Tape Reel
U74LVC1G3157L-KAP-R	U74LVC1G3157G-KAP-R	X1DFN14510-6	Tape Reel

<p>U74LVC1G3157G-AG6-R</p> <p>(1) Packing Type</p> <p>(2) Package Type</p> <p>(3) Green Package</p>	<p>(1) R: Tape Reel</p> <p>(2) AG6: SOT-26, AL6: SOT-363, KAP: X1DFN14510-6</p> <p>(3) G: Halogen Free and Lead Free, L: Lead Free</p>
---	--

### MARKING

SOT-26 / SOT-363	X1DFN14510-6

## ■ PIN CONFIGURATION

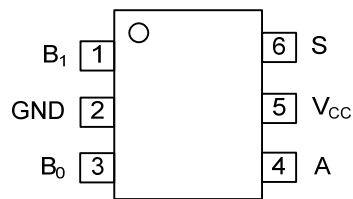

SOT-26 / SOT-363

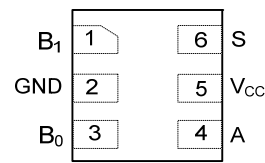

X1DFN14510-6  
(TOP VIEW)

## ■ PIN DESCRIPTION

PIN NO.	PIN NAME	DESCRIPTION
1	B1	Independent input or output
2	GND	Ground (0 V)
3	B0	Independent input or output
4	A	Common output or input
5	V <sub>CC</sub>	Supply voltage
6	S	Select input

## ■ FUNCTION TABLE

INPUT(S)	OUTPUT(Y)
L	B0 Connected to A
H	B1 Connected to A

H=High Level

L=Low Level

## ■ LOGIC DIAGRAM

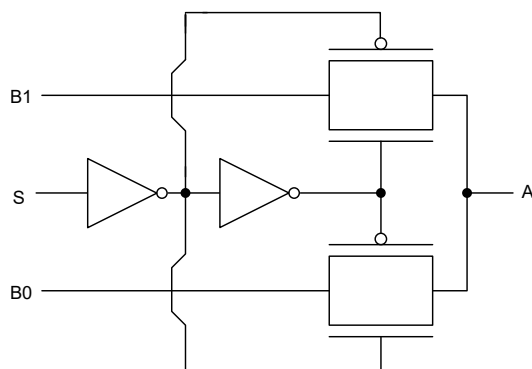

Logic Symbol

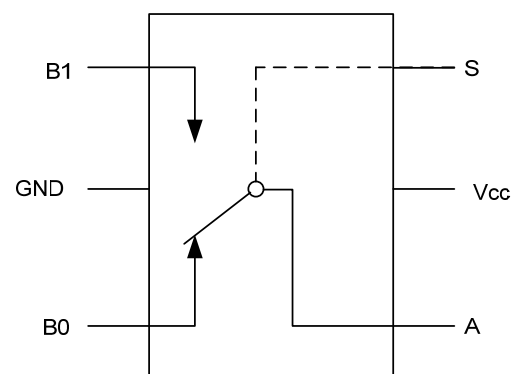

Analog Symbol

■ ABSOLUTE MAXIMUM RATING (Unless otherwise specified)

PARAMETER	SYMBOL	RATINGS	UNIT
Supply Voltage	V <sub>CC</sub>	-0.5 ~ +6.5	V
Switch Voltage	V <sub>S</sub>	-0.5 ~ V <sub>CC</sub> +0.5	V
Input Voltage	V <sub>IN</sub>	-0.5 ~ +6.5	V
V <sub>CC</sub> or GND Current	I <sub>CC</sub>	±100	mA
Continuous Output Current	I <sub>OUT</sub>	128	mA
Input Clamp Current (V <sub>IN</sub> <0V)	I <sub>IK</sub>	-50	mA
Junction Temperature	T <sub>J</sub>	+150	°C
Storage Temperature	T <sub>STG</sub>	-65 ~ + 150	°C

Note: Absolute maximum ratings are those values beyond which the device could be permanently damaged. Absolute maximum ratings are stress ratings only and functional device operation is not implied.

■ RECOMMENDED OPERATING CONDITIONS (Unless otherwise specified)

PARAMETER	SYMBOL	TEST CONDITIONS	MIN	TYP	MAX	UNIT
Supply Voltage	V <sub>CC</sub>		1.65		5.5	V
Control Input Voltage	V <sub>IN</sub>	(Note)	0		V <sub>CC</sub>	V
Switch Input Voltage	V <sub>IN</sub>	(Note)	0		V <sub>CC</sub>	V
Output Voltage	V <sub>OUT</sub>	(Note)	0		V <sub>CC</sub>	V
High-level Input Voltage	V <sub>IH</sub>	V <sub>CC</sub> =1.65V to 1.95V	0.75×V <sub>CC</sub>			V
		V <sub>CC</sub> =2.3V to 5.5V	0.7×V <sub>CC</sub>			V
Low-level Input Voltage	V <sub>IL</sub>	V <sub>CC</sub> =1.65V to 1.95V			0.25×V <sub>CC</sub>	V
		V <sub>CC</sub> =2.3V to 5.5V			0.3×V <sub>CC</sub>	V
Input Rise or Fall Times	$\frac{\Delta t}{\Delta V}$	Control Input V <sub>CC</sub> =2.3V~3.6V			10	ns/V
		Control Input V <sub>CC</sub> =4.5V~5.5V			5	ns/V
Operating Temperature	T <sub>A</sub>		-40		+125	°C

Note: Control input must be held HIGH or LOW; it must not float.

■ THERMAL DATA

PARAMETER	SYMBOL	RATINGS	UNIT
Junction to Ambient	SOT-26	230	°C/W
	SOT-363	330	°C/W
	X1DFN14510-6	400	°C/W
Junction to Case	SOT-26	90	°C/W
	SOT-363	110	°C/W
	X1DFN14510-6	260	°C/W

■ ELECTRICAL CHARACTERISTICS (Unless otherwise specified)

PARAMETER	SYMBOL	TEST CONDITIONS	T <sub>A</sub> =25°C			T <sub>A</sub> =-40~+125°C			UNIT
			MIN	TYP	MAX	MIN	TYP	MAX	
Switch On Resistance	R <sub>ON</sub>	V <sub>CC</sub> =4.5V, V <sub>IN</sub> =0V, I <sub>OUT</sub> =30mA		4	7		6	8	Ω
		V <sub>CC</sub> =4.5V, V <sub>IN</sub> =2.4V, I <sub>OUT</sub> =-30mA		7	12		7	13	Ω
		V <sub>CC</sub> =4.5V, V <sub>IN</sub> =4.5V, I <sub>OUT</sub> =-30mA		8	15		7	16	Ω
		V <sub>CC</sub> =3V, V <sub>IN</sub> =0V, I <sub>OUT</sub> =24mA		5	9		7	10	Ω
		V <sub>CC</sub> =3V, V <sub>IN</sub> =3V, I <sub>OUT</sub> =-24mA		11	20.0		9	20	Ω
		V <sub>CC</sub> =2.3V, V <sub>IN</sub> =0V, I <sub>OUT</sub> =8mA		6	12.0		8	13	Ω
		V <sub>CC</sub> =2.3V, V <sub>IN</sub> =2.3V, I <sub>OUT</sub> =-8mA		14	30.0		11	30	Ω
		V <sub>CC</sub> =1.65V, V <sub>IN</sub> =0V, I <sub>OUT</sub> =4mA		10	20.0		11	20	Ω
		V <sub>CC</sub> =1.65V, V <sub>IN</sub> =1.65V, I <sub>OUT</sub> =-4mA		16	50.0		17	50	Ω
On Resistance Match Between Channel	ΔR <sub>ON</sub>	V <sub>CC</sub> =4.5V, V <sub>BN</sub> =3.15V, I <sub>A</sub> =-30mA		0.15			0.2		Ω
		V <sub>CC</sub> =3V, V <sub>BN</sub> =2.1V, I <sub>A</sub> =-24mA		0.2			0.3		Ω
		V <sub>CC</sub> =2.3V, V <sub>BN</sub> =1.6V, I <sub>A</sub> =-8mA		0.5			0.5		Ω
		V <sub>CC</sub> =1.65V, V <sub>BN</sub> =1.15V, I <sub>A</sub> =-4mA		0.5			0.5		Ω
Input Leakage Current	I <sub>I(LEAK)</sub>	V <sub>CC</sub> =0 to 5.5V, 0≤V <sub>IN</sub> ≤5.5V			±0.1			±0.1	μA
Off State Leakage Current	I <sub>OFF</sub>	V <sub>CC</sub> =1.65 to 5.5V, 0≤A,B≤V <sub>CC</sub>			±0.1			±0.1	μA
Quiescent Supply Current	I <sub>Q</sub>	V <sub>CC</sub> =5.5V, V <sub>IN</sub> =V <sub>CC</sub> or GND, I <sub>OUT</sub> =0			1			±1	μA
Analog Signal Range		V <sub>CC</sub> =V <sub>CC</sub> , V <sub>IN</sub> =V <sub>CC</sub> or GND	0		V <sub>CC</sub>	0		V <sub>CC</sub>	V

■ SWITCHING CHARACTERISTICS (see TEST CIRCUIT AND WAVEFORMS)

PARAMETER	SYMBOL	TEST CONDITIONS	T <sub>A</sub> =25°C			T <sub>A</sub> =-40~+125°C			UNIT	
			MIN	TYP	MAX	MIN	TYP	MAX		
Propagation Delay Bus to Bus(Note)	t <sub>PLH</sub> t <sub>PHL</sub>	C <sub>L</sub> =50 pF, R <sub>L</sub> =500Ω	V <sub>CC</sub> =1.65 ~ 1.95V			4.5			5.0	ns
			V <sub>CC</sub> =2.3 ~ 2.7V			2.0			2.5	ns
			V <sub>CC</sub> =3.0 ~ 3.6V			1.0			1.5	ns
			V <sub>CC</sub> =4.5 ~ 5.5V			0.5			0.7	ns
Output Enable Time Turn-On Time (A to B <sub>N</sub> )	t <sub>pZL</sub> t <sub>pZH</sub>	C <sub>L</sub> =50 pF, R <sub>L</sub> =500Ω	V <sub>CC</sub> =1.65 ~ 1.95V	1.0		23.0	1.0		25	ns
			V <sub>CC</sub> =2.3 ~ 2.7V	1.0		13.0	1.0		15	ns
			V <sub>CC</sub> =3.0 ~ 3.6V	1.0		7.0	1.0		9.0	ns
			V <sub>CC</sub> =4.5 ~ 5.5V	0.5		5.5	0.5		7.0	ns
Output Enable Time Turn-Off Time (A to B <sub>N</sub> )	t <sub>PHZ</sub> t <sub>PLZ</sub>	C <sub>L</sub> =50 pF, R <sub>L</sub> =500Ω	V <sub>CC</sub> =1.65 ~ 1.95V	1.0		13.0	1.0		15	ns
			V <sub>CC</sub> =2.3 ~ 2.7V	1.0		7.0	1.0		9.0	ns
			V <sub>CC</sub> =3.0 ~ 3.6V	1.0		5.0	1.0		6.0	ns
			V <sub>CC</sub> =4.5 ~ 5.5V	0.5		4.0	0.5		5.0	ns

Note: Guaranteed by design.

■ DYNAMIC CHARACTERISTICS (Unless otherwise specified)

PARAMETER	SYMBOL	TEST CONDITIONS	MIN	TYP	MAX	UNIT	
Bandwidth	BW	R <sub>L</sub> =50Ω, Switch ON	V <sub>CC</sub> =1.8V		220		MHz
			V <sub>CC</sub> =2.3V		220		MHz
			V <sub>CC</sub> =3.0V		220		MHz
			V <sub>CC</sub> =4.5V		220		MHz
OFF Isolation	O <sub>ISO</sub>	R <sub>L</sub> =50Ω, f=10MHz, Switch OFF	V <sub>CC</sub> =1.8V		-60		dB
			V <sub>CC</sub> =2.3V		-65		dB
			V <sub>CC</sub> =3.0V		-65		dB
			V <sub>CC</sub> =4.5V		-65		dB
Crosstalk	X <sub>TALK</sub>	R <sub>L</sub> =50Ω, f=10MHz, Switch ON	V <sub>CC</sub> =1.8V		-66		dB
			V <sub>CC</sub> =2.3V		-66		dB
			V <sub>CC</sub> =3.0V		-66		dB
			V <sub>CC</sub> =4.5V		-66		dB
Total Harmonic Distortion	THD	R <sub>L</sub> =600Ω, C <sub>L</sub> =50pF, f=600Hz~20KHz	V <sub>CC</sub> =1.8V		0.015		%
			V <sub>CC</sub> =2.3V		0.025		%
			V <sub>CC</sub> =3.0V		0.015		%
			V <sub>CC</sub> =4.5V		0.01		%

■ OPERATING CHARACTERISTICS (Unless otherwise specified)

PARAMETER	SYMBOL	TEST CONDITIONS	MIN	TYP	MAX	UNIT
Control Pin Input Capacitance	C <sub>IN</sub>	V <sub>CC</sub> =0V		2.3		pF
B Port Off Capacitance	C <sub>IO-B</sub>	V <sub>CC</sub> =5.0V		6.5		pF
A Port Capacitance When Switch Is Enabled	C <sub>IOA-ON</sub>	V <sub>CC</sub> =5.0V		18.5		pF

■ TEST CIRCUIT AND WAVEFORMS

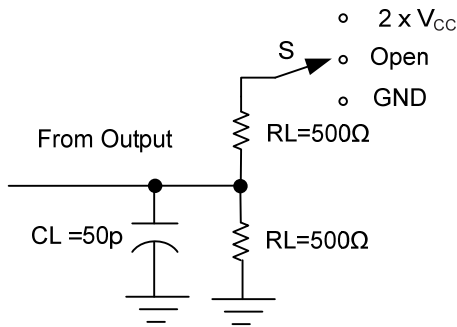

TEST CIRCUIT

TEST	S
$t_{PLH}/t_{PHL}$	Open
$t_{PHZ}/t_{PZH}$	GND
$t_{PLZ}/t_{PZL}$	$2 \times V_{CC}$

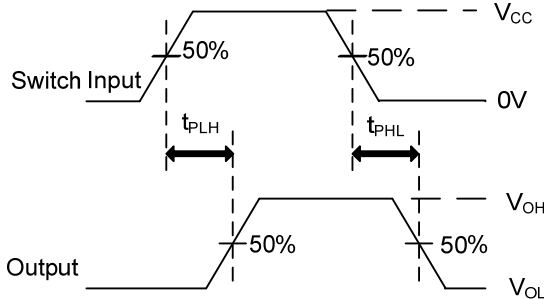

VOLTAGE WAVEFORMS  
PROPAGATION DELAY TIMES

Note:  $C_L$  includes probe and jig capacitance.  
 $PRR \leq 1\text{MHz}$ ,  $Z_o = 50\Omega$ ,  $t_r \leq 2.5\text{ns}$ ,  $t_f \leq 2.5\text{ns}$ .

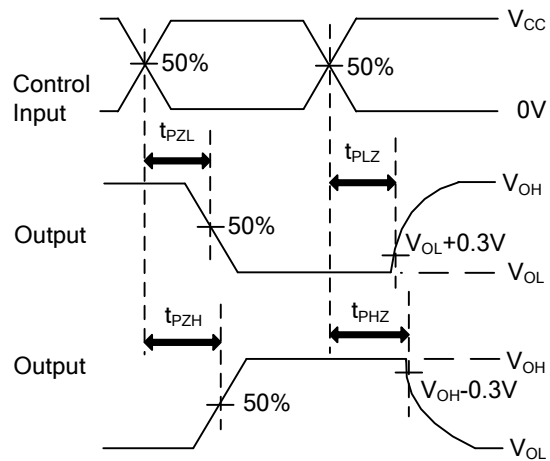

VOLTAGE WAVEFORMS  
ENABLE AND DISABLE TIMES

UTC assumes no responsibility for equipment failures that result from using products at values that exceed, even momentarily, rated values (such as maximum ratings, operating condition ranges, or other parameters) listed in products specifications of any and all UTC products described or contained herein. UTC products are not designed for use in life support appliances, devices or systems where malfunction of these products can be reasonably expected to result in personal injury. Reproduction in whole or in part is prohibited without the prior written consent of the copyright owner. UTC reserves the right to make changes to information published in this document, including without limitation specifications and product descriptions, at any time and without notice. This document supersedes and replaces all information supplied prior to the publication hereof.