



US5C3306

Preliminary

CMOS IC

2-BIT BUS SWITCH WITH ACTIVE LOW ENABLES

DESCRIPTION

The UTC **US5C3306** consist of two independent 5Ω switches with fast individual enables. The “A” pin is connected to the “B” pin directly when the associated Bus Enable (BE) pin is set to “Low”. The bus switch introduces no additional propagation delay or additional ground bounce noise.

FEATURES

- * Low on-resistor between two ports (5Ω typical)
- * Near-Zero propagation delay
- * Direct bus connection when switches are ON
- * Ultra Low Quiescent Power (0.2μA typical)
 - Ideally suited for notebook applications

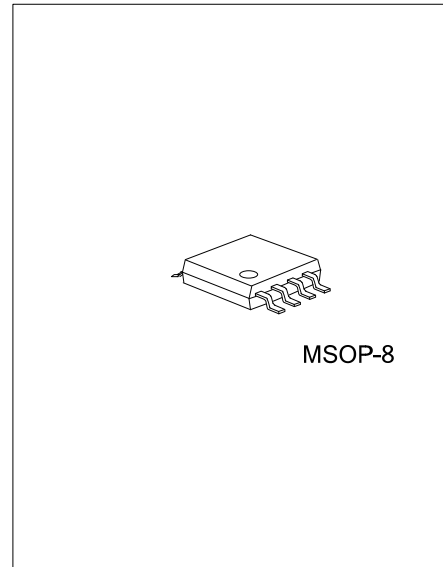

ORDERING INFORMATION

Ordering Number	Package	Packing
US5C3306G-SM1-R	MSOP-8	Tape Reel

<p>US5C3306G-SM1-R</p> <ul style="list-style-type: none"> (1)Packing Type (2)Package Type (3)Green Package 	<ul style="list-style-type: none"> (1) R: Tape Reel (2) SM1: MSOP-8 (3) G: Halogen Free and Lead Free
---	--

MARKING

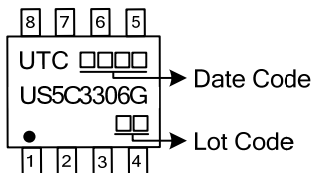

■ PIN CONFIGURATION

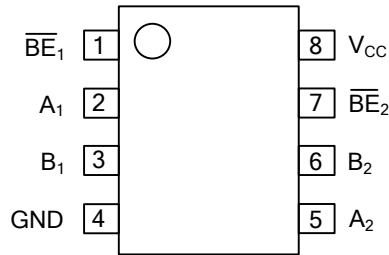

■ PIN DESCRIPTION

PIN NO.	PIN NAME	DESCRIPTION
1, 7	BE _n	Switch Enable
2, 5	A1, A2	Bus A
3, 6	B1, B2	Bus B
4	GND	Ground
8	V _{CC}	Power

■ TRUTH TABLE (Note 1)

\overline{BE}_n	A _n	B _n	V _{CC}	Function
X (Note 2)	Hi-Z	Hi-Z	GND	Disconnect
H	Hi-Z	Hi-Z	V _{CC}	Disconnect
L	B _n	A _n	V _{CC}	Connect

Notes: 1. H=High Voltage Level, L=Low Voltage Level

Hi-Z=High Impedance, X=Don't Care

2. A pull-up resistor should be provided for power-up protection.

■ BLOCK DIAGRAM

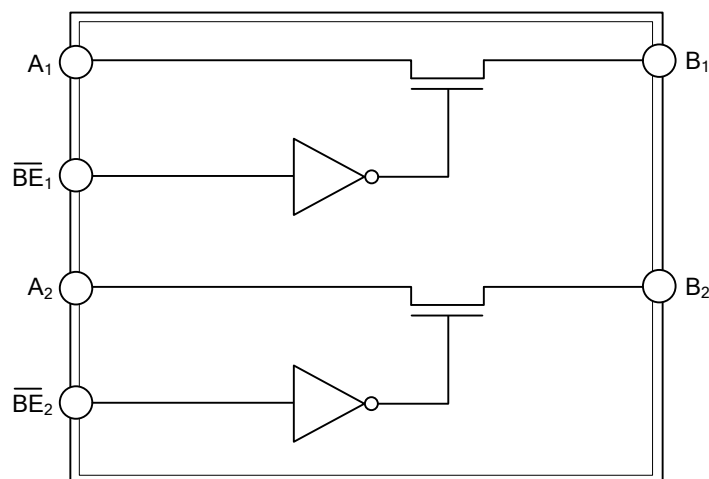

- ABSOLUTE MAXIMUM RATING (Above which the useful life may be impaired. For user guidelines, not tested.)

PARAMETER	SYMBOL	RATINGS	UNIT
Supply Voltage to Ground Potential		-0.5~+7.0	V
DC Input Voltage		-0.5~+7.0	V
DC Output Current		120	mA
Power Dissipation	P_D	0.5	W
Storage Temperature	T_{STG}	-65~+150	°C
Ambient Temperature with Power Applied	T_A	-40~+85	°C

Note: Absolute maximum ratings are those values beyond which the device could be permanently damaged. Absolute maximum ratings are stress ratings only and functional device operation is not implied.

■ DC ELECTRICAL CHARACTERISTICS

(Over the Operating Range, $T_A=-40^{\circ}\text{C}\sim+85^{\circ}\text{C}$, $V_{CC}=5.0\text{V}\pm 10\%$)

PARAMETER	SYMBOL	TEST CONDITIONS (Note 1)	MIN	TYP (Note 2)	MAX	UNIT
Input HIGH Voltage	V_{IH}	Guaranteed Logic HIGH Level	2.0			V
Input LOW Voltage	V_{IL}	Guaranteed Logic LOW Level	-0.5		0.8	V
Input HIGH Current	I_{IH}	$V_{CC}=\text{Max.}$, $V_{IN}=V_{CC}$			± 1	μA
Input LOW Current	I_{IL}	$V_{CC}=\text{Max.}$, $V_{IN}=\text{GND}$			± 1	μA
High Impedance Output Current	I_{OZ}	$0\leq A$, $B\leq V_{CC}$			± 1	μA
Input Hysteresis at Control Pins	V_H			300		mV
Switch On-Resistance (Note 3)	R_{ON}	$V_{CC}=4.5\text{V}$, $V_{IN}=0.0\text{V}$, $I_{ON}=30\text{mA}$ or 64mA		5	7	Ω
		$V_{CC}=4.5\text{V}$, $V_{IN}=2.4\text{V}$, $I_{ON}=-15\text{mA}$		10	15	Ω

- Notes: 1. For Max. or Min. conditions, use appropriate value specified under Electrical Characteristics for the applicable device type
 2. Typical values are at $V_{CC}=5.0\text{V}$, $T_A=25^{\circ}\text{C}$ ambient and maximum loading.
 3. Measured by the voltage drop between A and B pin at indicated current through the switch. On-Resistance is determined by the lower of the voltages on the two (A, B) pin

■ POWER SUPPLY CHARACTERISTICS

PARAMETER	SYMBOL	TEST CONDITIONS (Note 1)	MIN	TYP (Note 2)	MAX	UNIT
Quiescent Power Supply Current	I_{CC}	$V_{IN}=\text{GND}$ or V_{CC}		0.1	3.0	μA
Supply Current per Input @ TTL HIGH	ΔI_{CC}	$V_{CC}=\text{Max.}$, $V_{IN}=3.4\text{V}$ (Note 3)			2.5	mA

- Notes: 1. For Max. or Min. conditions, use appropriate value specified under Electrical Characteristics for the applicable device.
 2. Typical values are at $V_{CC}=5.0\text{V}$, $+25^{\circ}\text{C}$ ambient.
 3. Per TTL driven input ($V_{IN}=3.4\text{V}$, control inputs only); A and B pins do not contribute to I_{CC} .

■ CAPACITANCE ($T_A=25^{\circ}\text{C}$, $f=1\text{MHz}$)

PARAMETER (Note 1)	SYMBOL	TEST CONDITIONS (Note 1)	MIN	TYP	MAX	UNIT
Input Capacitance	C_{IN}	$V_{IN}=0\text{V}$		3		pF
A/B Capacitance, Switch Off	C_{OFF}			5		pF
A/B Capacitance, Switch On	C_{ON}			10		pF

Note: This parameter is determined by device characterization but is not production tested.

■ SWITCHING CHARACTERISTICS OVER OPERATING RANGE

($C_L=50\text{pF}$, $R_L=500\Omega$; $R_P=500\Omega$ (Note 3))

PARAMETER	SYMBOL	TEST CONDITIONS (Note 1)	MIN	TYP	MAX	UNIT
Propagation Delay (Note 1, 2) A to B, B to A	t_{PLH}/t_{PHL}	$V_{CC}=4\text{V}$			0.25	ns
		$V_{CC}=5\text{V}\pm 10\%$			0.25	ns
Bus Enable Time	t_{PZH}/t_{PZL}	$V_{CC}=4\text{V}$			5.5	ns
		$V_{CC}=5\text{V}\pm 10\%$	1.0		4.9	ns
Bus Disable Time	t_{PHZ}/t_{PLZ}	$V_{CC}=4\text{V}$			4.5	ns
		$V_{CC}=5\text{V}\pm 10\%$	1.0		4.2	ns

Notes: 1. This parameter is guaranteed but not tested on Propagation Delays.

2. The bus switch contributes no propagational delay other than the RC delay of the On-Resistance of the switch and the load capacitance. The time constant for the switch alone is of the order of 0.25ns for 50pF load. Since this time constant is much smaller than the rise/fall times of typical driving signals, it adds very little propagational delay to the system. Propagational delay of the bus switch when used in a system is determined by the driving circuit on the driving side of the switch and its interaction with the load on the driven side.

3. RP terminates to 7V supply for t_{PZL} and t_{PLZ} measurement.

■ TEST CIRCUIT

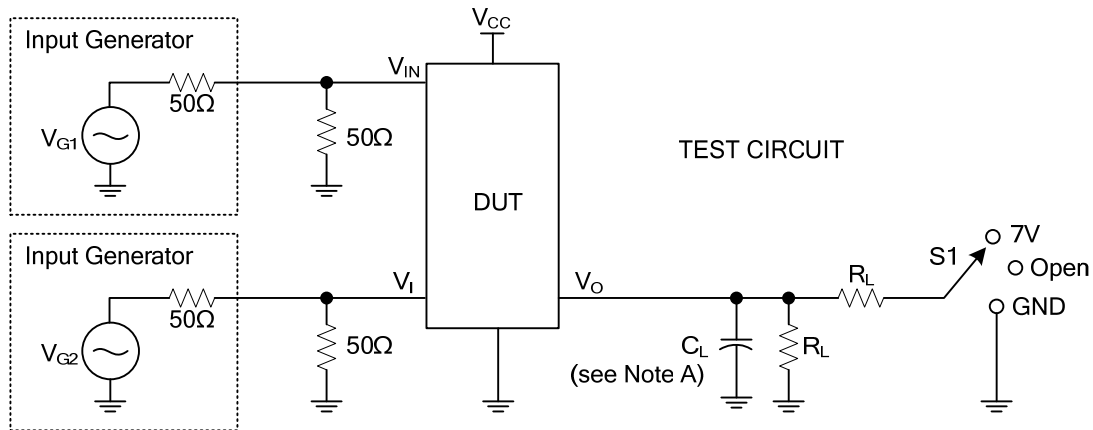

■ SWITCH POSITIONS

TEST	S1	R _L	V _I	C _L	V _Δ
T _{PD(S)}	Open	500Ω	V _{CC} or GND	50pF	
T _{PLZ} /T _{PZL}	7V	500Ω	GND	50pF	0.3V
T _{PHZ} /T _{PZH}	GND	500Ω	V _{CC}	50pF	0.3V

■ ENABLE AND DISABLE TIMING

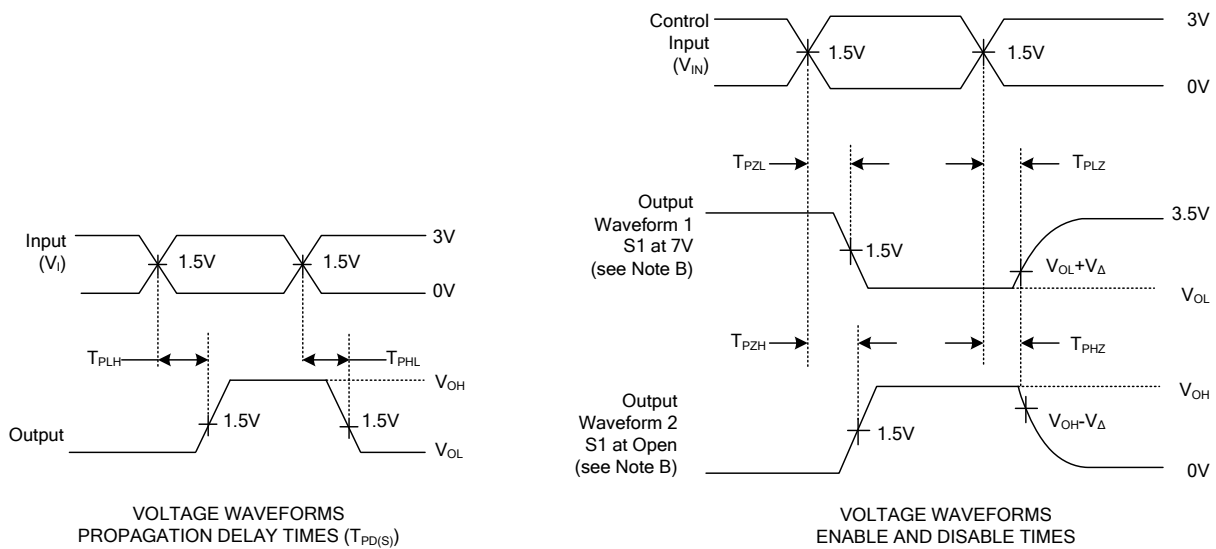

- Notes:
1. C_L includes probe and jig capacitance.
 2. Waveform 1 is for an output with internal conditions such that the output is low, except when disabled by the output control. Waveform 2 is for an output with internal conditions such that the output is high, except when disabled by the output control.
 3. All input pulses are supplied by generators having the following characteristics: PRR≤10MHz, Z_O=50Ω, T_R≤2.5ns, T_F≤2.5ns.
 4. The outputs are measured one at a time, with one transition per measurement.
 5. T_{PLZ} and T_{PHZ} are the same as T_{DISABLE}.
 6. T_{PZL} and T_{PZH} are the same as T_{ENABLE}.
 7. T_{PLH} and T_{PHL} are the same as T_{PD(S)}.
 8. All parameters and waveforms are not applicable to all devices.

UTC assumes no responsibility for equipment failures that result from using products at values that exceed, even momentarily, rated values (such as maximum ratings, operating condition ranges, or other parameters) listed in products specifications of any and all UTC products described or contained herein. UTC products are not designed for use in life support appliances, devices or systems where malfunction of these products can be reasonably expected to result in personal injury. Reproduction in whole or in part is prohibited without the prior written consent of the copyright owner. The information presented in this document does not form part of any quotation or contract, is believed to be accurate and reliable and may be changed without notice.