



L6134

Preliminary

LINEAR INTEGRATED CIRCUIT

LOW POWER 10 MHZ RAIL-TO-RAIL I/O QUAD OPERATIONAL AMPLIFIERS

DESCRIPTION

The UTC **L6134** provides new levels of speed vs power performance in applications where low voltage supplies or power limitations previously made compromise necessary. With only 350µA/amp supply current, the 10MHz gain-bandwidth of this device supports new portable applications where higher power devices unacceptably drain battery life.

The UTC **L6134** can be driven by voltages that exceed both power supply rails, thus eliminating concerns over exceeding the common-mode voltage range. The rail-to-rail output swing capability provides the maximum possible dynamic range at the output. This is particularly important when operating on low supply voltages. The UTC **L6134** can also drive large capacitive loads without oscillating.

Operating on supplies from 2.7V to over 24V, the UTC **L6134** is excellent for a very wide range of applications, from battery operated systems with large bandwidth requirements to high speed instrumentation.

FEATURES

- * (For 5V Supply, Typ. Unless Noted)
- * Rail-to-rail Input : -0.25V ~ 5.25V
- * Rail-to-Rail Output : 0.01V ~ 4.99V
- * High Gain-Bandwidth, 10MHz at 20kHz
- * Slew Rate 12V/µs
- * Low Supply Current 350µA/Amplifier
- * Wide Supply Range: 2.7V ~ 24V
- * Gain 100dB with $R_L=10k$

ORDERING INFORMATION

Ordering Number		Package	Packing
Lead Free	Halogen Free		
L6134L-S14-R	L6134G-S14-R	SOP-14	Tape Reel

<p>L6134G-S14-R</p> <ul style="list-style-type: none"> (1)Packing Type (2)Package Type (3)Green Package 	<ul style="list-style-type: none"> (1) R: Tape Reel (2) S14: SOP-14 (3) G: Halogen Free and Lead Free, L: Lead Free
--	--

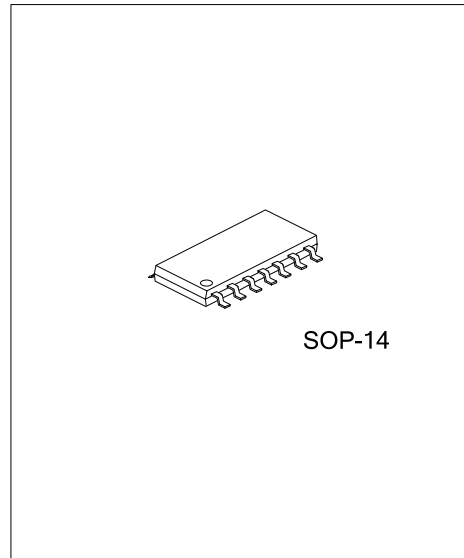

MARKING

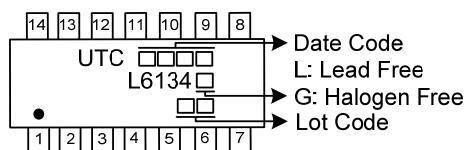

PIN CONFIGURATION

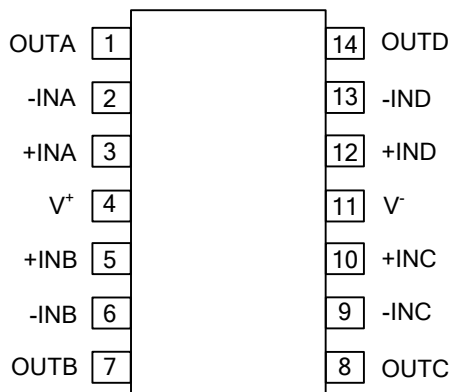

PIN DESCRIPTION

PIN NO.	PIN NAME	I/O	DESCRIPTION
1	OUTA	O	Analog Output pin of A AMP
2	-INA	I	Inverting Input pin of A AMP
3	+INA	I	Non-inverting Input of A AMP
4	V ⁺	I	Positive Power Supply
5	+INB	I	Non-inverting Input of B AMP
6	-INB	I	Inverting Input pin of B AMP
7	OUTB	O	Analog Output pin of B AMP
8	OUTC	O	Analog Output pin of C AMP
9	-INC	I	Inverting Input pin of C AMP
10	+INC	I	Non-inverting Input of C AMP
11	V ⁻	I	Negative Power Supply
12	+IND	I	Non-inverting Input of D AMP
13	-IND	I	Inverting Input pin of D AMP
14	OUTD	O	Analog Output pin of D AMP

■ BLOCK DIAGRAM

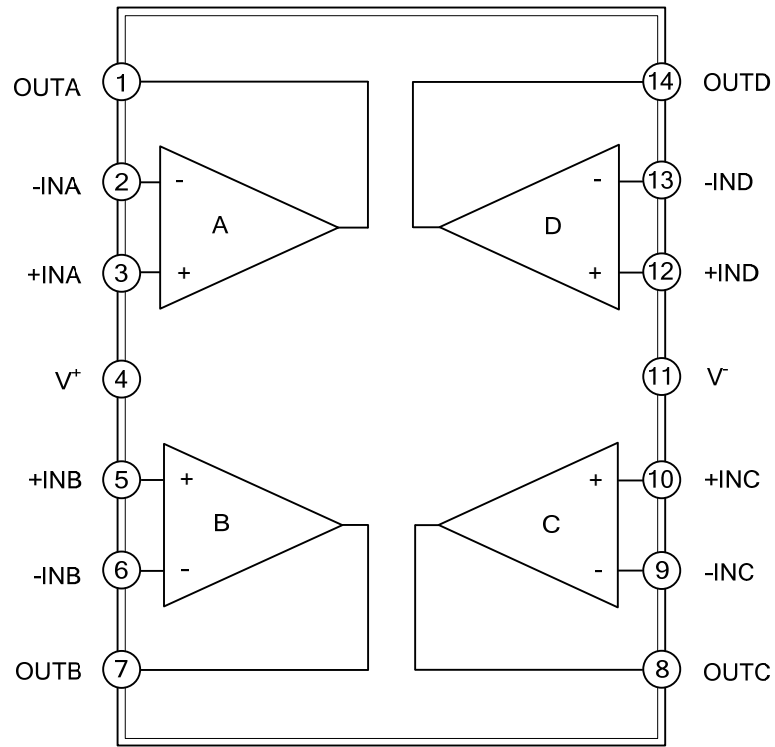

■ ABSOLUTE MAXIMUM RATINGS (Note 1)

PARAMETER	SYMBOL	RATINGS	UNIT
Differential Input Voltage		±15	V
Voltage at Input/Output Pin		(V ⁺) + 0.3, (V ⁻) - 0.3	V
Supply Voltage (V ⁺ - V ⁻)		35	V
Current at Input Pin		±10	mA
Current at Output Pin (Note 2)		±25	mA
Current at Power Supply Pin		50	mA
Junction Temperature	T _J	+150	°C
Storage Temperature	T _{STG}	-65 ~ +150	°C

- Notes: 1. Absolute maximum ratings are those values beyond which the device could be permanently damaged. Absolute maximum ratings are stress ratings only and functional device operation is not implied.
 2. Applies to both single-supply and split-supply operation. Continuous short circuit operation at elevated ambient temperature can result in exceeding the maximum allowed junction temperature of 150°C.

■ RECOMMENDED OPERATING CONDITIONS

PARAMETER	SYMBOL	TEST CONDITIONS	MIN	TYP	MAX	UNIT
Supply Voltage	V ⁺		2.7		24	V
Temperature Range	T _A		-40		+85	°C

■ 5V DC ELECTRICAL CHARACTERISTICS (Note 1)

(V⁺ = 5.0V, V⁻ = 0V, V_{CM} = V_O = V⁺/2 and R_L > 1MΩ to V⁺/2, T_C = 25°C, unless otherwise specified)

PARAMETER	SYMBOL	TEST CONDITIONS	MIN (Note 3)	TYP (Note 2)	MAX (Note 3)	UNIT	
Input Offset Voltage	V _{OS}	T _A = 25°C		4.0	8.0	mV	
Input Bias Current	I _B	0V ≤ V _{CM} ≤ 5V		110		nA	
Input Offset Current	I _{OS}			3	50	nA	
Input Resistance, CM	R _{IN}			104		MΩ	
Common-Mode Rejection Ratio	CMRR	0V ≤ V _{CM} ≤ 4V	70	100		dB	
		0V ≤ V _{CM} ≤ 5V	55	80		dB	
Power Supply Rejection Ratio	PSRR	±2.5V ≤ V + ≤ ±12V	78	87		dB	
Input Common-Mode Voltage Range	V _{CM}		0	-0.25 ~5.25	5.0	V	
Large Signal Voltage Gain	A _V	R _L = 10k	6	100		V/mV	
Output Swing	V _{OH}	R _L = 100k	4.93	4.98		V	
		R _L = 10k	4.85	4.94		V	
		R _L = 5k	4.85	4.9		V	
	V _{OL}	R _L = 100k		0.019	0.017		V
		R _L = 10k		0.07	0.09		V
		R _L = 5k		0.095	0.12		V
Output Short Circuit Current	I _{SC}	Sourcing	1	2		mA	
		Sinking	0.7	1.3		mA	
Supply Current	I _S	Per Amplifier		350	450	μA	

- Notes: 1. Electrical Table values apply only for factory testing conditions at the temperature indicated. Factory testing conditions result in very limited self-heating of the device such that T_J = T_A. No guarantee of parametric performance is indicated in the electrical tables under conditions of the internal self heating where T_J > T_A.
 2. All voltage values, except differential voltage, are with respect to network ground terminal.
 3. Typical values represent the most likely parametric norm.
 4. All limits are guaranteed by testing or statistical analysis.
 5. Input current must be limited by a resistor in series with the inputs.

■ 5V AC ELECTRICAL CHARACTERISTICS (Note 1)

($V^+ = 5.0V$, $V^- = 0V$, $V_{CM} = V_O = V^+/2$ and $R_L > 1M\Omega$ to $V^+/2$, $T_C = 25^\circ C$, unless otherwise specified)

PARAMETER	SYMBOL	TEST CONDITIONS	MIN (Note 3)	TYP (Note 2)	MAX	UNIT
Slew Rate	SR	$\pm 4V$ @ $V_S = \pm 6V$, $R_S > 1k\Omega$	5	14		V/ μs
Gain-Bandwidth Product	GBW	$f = 20kHz$	7	10		MHz
Phase Margin	ϕ_m	$R_L = 10k$		33		Deg
Amp-to-Amp Isolation		$R_L = 10k$		10		dB
Input-Referred Voltage Noise	e_n	$f = 1kHz$		27		nV/ \sqrt{Hz}
Input-Referred Current Noise	i_n	$f = 1kHz$		0.18		pA/ \sqrt{Hz}

- Notes: 1. Electrical Table values apply only for factory testing conditions at the temperature indicated. Factory testing conditions result in very limited self-heating of the device such that $T_J = T_A$. No guarantee of parametric performance is indicated in the electrical tables under conditions of the internal self heating where $T_J > T_A$.
2. Typical values represent the most likely parametric norm.
3. All limits are guaranteed by testing or statistical analysis.

■ 2.7V DC ELECTRICAL CHARACTERISTICS (Note 1)

($V^+ = 2.7V$, $V^- = 0V$, $V_{CM} = V_O = V^+/2$ and $R_L > 1M\Omega$ to $V^+/2$, $T_C = 25^\circ C$, unless otherwise specified)

PARAMETER	SYMBOL	TEST CONDITIONS	MIN (Note 3)	TYP (Note 2)	MAX (Note 3)	UNIT
Input Offset Voltage	V_{OS}			0.12	12	mV
Input Bias Current	I_B	$0V \leq V_{CM} \leq 2.7V$		90		nA
Input Offset Current	I_{OS}			2.8		nA
Input Resistance, C_M	R_{IN}			134		M Ω
Common-Mode Rejection Ratio	CMRR	$0V \leq V_{CM} \leq 2.7V$		82		dB
Power Supply Rejection Ratio	PSRR	$\pm 1.35V \leq V \leq \pm 12V$		80		dB
Input Common-Mode Voltage Range	V_{CM}		0		2.7	V
Large Signal Voltage Gain	A_V	$R_L = 10k$		100		V/mV
Output Swing	V_{OH}	$R_L = 100k\Omega$	2.25	2.66		V
	V_{OL}	$R_L = 100k\Omega$		0.03	0.112	V
Supply Current	I_S	Per Amplifier		250		μA

- Notes: 1. Electrical Table values apply only for factory testing conditions at the temperature indicated. Factory testing conditions result in very limited self-heating of the device such that $T_J = T_A$. No guarantee of parametric performance is indicated in the electrical tables under conditions of the internal self heating where $T_J > T_A$.
2. Typical values represent the most likely parametric norm.
3. All limits are guaranteed by testing or statistical analysis.

■ 2.7V AC ELECTRICAL CHARACTERISTICS (Note 1)

($V^+ = 2.7V$, $V^- = 0V$, $V_{CM} = V_O = V^+/2$ and $R_L > 1M\Omega$ to $V^+/2$, $T_C = 25^\circ C$, unless otherwise specified)

PARAMETER	SYMBOL	TEST CONDITIONS	MIN (Note 3)	TYP (Note 2)	MAX	UNIT
Gain-Bandwidth Product	GBW	$R_L = 10k$, $f = 20kHz$		7		MHz
Phase Margin	ϕ_m	$R_L = 10k$		23		Deg
Gain Margin	G_m			12		dB

- Notes: 1. Electrical Table values apply only for factory testing conditions at the temperature indicated. Factory testing conditions result in very limited self-heating of the device such that $T_J = T_A$. No guarantee of parametric performance is indicated in the electrical tables under conditions of the internal self heating where $T_J > T_A$.
2. Typical values represent the most likely parametric norm.
3. All limits are guaranteed by testing or statistical analysis.

■ 24V ELECTRICAL CHARACTERISTICS (Note 1)

($V^+ = 24V$, $V^- = 0V$, $V_{CM} = V_O = V^+/2$ and $R_L > 1M\Omega$ to $V^+/2$, $T_C = 25^\circ C$, unless otherwise specified)

PARAMETER	SYMBOL	TEST CONDITIONS	MIN (Note 3)	TYP (Note 2)	MAX (Note 3)	UNIT
Input Offset Voltage	V_{OS}			1.7	9.0	mV
Input Bias Current	I_B			125		nA
Input Offset Current	I_{OS}			4.8		nA
Input Resistance, C_M	R_{IN}			210		M Ω
Common-Mode Rejection Ratio	CMRR	$0V \leq V_{CM} \leq 24V$		80		dB
Power Supply Rejection Ratio	PSRR	$2.7V \leq V^+ \leq 24V$		82		dB
Input Common-Mode Voltage Range	V_{CM}		0	-0.25~ 24.25	24	V
Large Signal Voltage Gain	A_V	$R_L = 10k$		102		V/mV
Output Swing	V_{OH}	$R_L = 10k\Omega$	23.8	23.86		V
	V_{OL}	$R_L = 10k\Omega$		0.075	0.15	V
Supply Current	I_S	Per Amplifier		390	490	μA
Gain-Bandwidth Product	GBW	$R_L = 10k$, $f = 20$ kHz		11		MHz

- Notes: 1. Electrical Table values apply only for factory testing conditions at the temperature indicated. Factory testing conditions result in very limited self-heating of the device such that $T_J = T_A$. No guarantee of parametric performance is indicated in the electrical tables under conditions of the internal self heating where $T_J > T_A$.
2. Typical values represent the most likely parametric norm.
3. All limits are guaranteed by testing or statistical analysis.

UTC assumes no responsibility for equipment failures that result from using products at values that exceed, even momentarily, rated values (such as maximum ratings, operating condition ranges, or other parameters) listed in products specifications of any and all UTC products described or contained herein. UTC products are not designed for use in life support appliances, devices or systems where malfunction of these products can be reasonably expected to result in personal injury. Reproduction in whole or in part is prohibited without the prior written consent of the copyright owner. UTC reserves the right to make changes to information published in this document, including without limitation specifications and product descriptions, at any time and without notice. This document supersedes and replaces all information supplied prior to the publication hereof.