



CJ6111 Series Low-dropout Regulators

1 Introduction

The CJ6111 series is a group of low-dropout voltage, positive voltage regulators manufactured using CMOS technology. Its input voltage can support up to 6.5V, and it can provide up to 300mA of output current with good heat dissipation. Even if the voltage difference between input and output is small, it can still provide a large output current. The typical quiescent current value of the CJ6111 series is as low as 0.8 μ A, with internal integration of current limiting protection, short circuit protection, thermal shutdown, and excellent load transient response.

The CJ6111 series can use ceramic capacitors, which can help save the size of printed circuit boards (PCBs). Therefore, the CJ6111 series is very suitable for battery powered devices, such as RF applications and other systems that require quiet voltage sources, to improve the efficiency of these systems and extend the battery life of the devices.

2 Applications

- Wearable Electronics
- Ultrabooks, Tablets, E-readers
- Always-on Power Supplies
- Set-top Boxes
- Gaming Controllers, Remote controls, Toys, Drones
- Wireless Handsets and Smart Phones
- Portable and Battery-powered Equipment

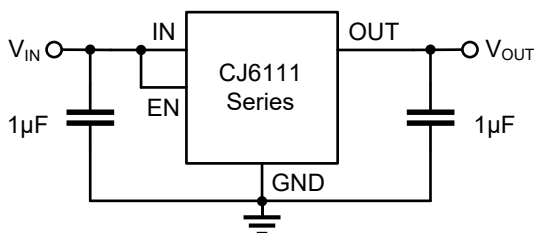

Typical Application Circuit

3 Features

- Input Voltage Range: 2.0V ~ 6.5V
- Fixed Output Voltage:
Designed for 1.0V to 5.0V Output
Output Voltage Tolerance: $\pm 1\%$
- Output Current: up to 300mA
- Low Quiescent Current:
Typical: 0.8 μ A
Low I_Q in Dropout Mode
- Dropout Voltage:
120mV@100mA ($V_{OUT} = 3.3V$)
- Power Supply Rejection Ratio:
80dB@1kHz
- Output Noise Voltage:
 $25 \times V_{OUT} \mu V_{RMS}$ (10Hz ~ 100kHz)
- Temperature Characteristics:
Typical: 15ppm/ $^{\circ}C$
No Drift-up under High Temperature during no-load Operation
- Fast Transient Response
- Soft Start Function
- Integrated Fault Protection:
Built-in Current Limit
Short-Circuit Protection
Thermal Shutdown

4 Available Packages

PART NUMBER	PACKAGE
CJ6111 Series	SOT-23-3L
	DFNWB1 \times 1-4L
	SOT-23-5L

Note: For all available packages, please refer to the part *Orderable Information*.

5 Orderable Information

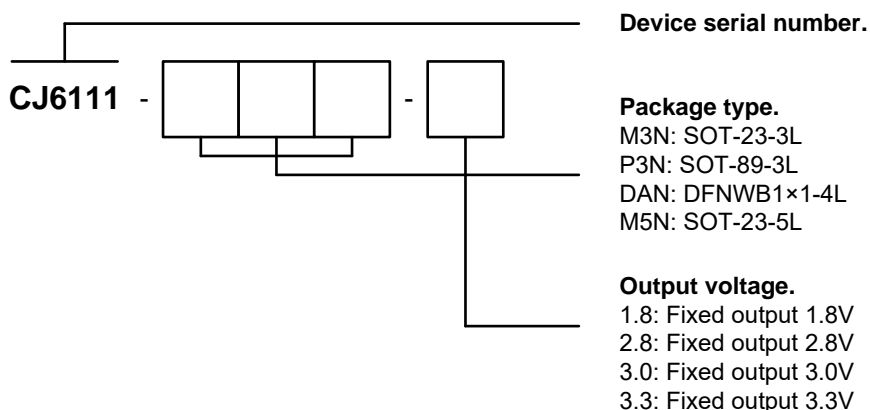

Figure 5-1. Naming Conventions

MODEL	DEVICE	PACKAGE	OP TEMP	ECO PLAN	MSL	PACKING OPTION	SORT
3 Pins Packaged Products							
CJ6111-1.8	CJ6111-M3N-1.8	SOT-23-3L	-40 ~ 85°C	RoHS & Green	Level 3 168 HR	Tape and Reel 3000 Units / Reel	Active
CJ6111-2.8	CJ6111-M3N-2.8	SOT-23-3L	-40 ~ 85°C	RoHS & Green	Level 3 168 HR	Tape and Reel 3000 Units / Reel	Active
CJ6111-3.0	CJ6111-M3N-3.0	SOT-23-3L	-40 ~ 85°C	RoHS & Green	Level 3 168 HR	Tape and Reel 3000 Units / Reel	Active
CJ6111-3.3	CJ6111-M3N-3.3	SOT-23-3L	-40 ~ 85°C	RoHS & Green	Level 3 168 HR	Tape and Reel 3000 Units / Reel	Active
4 Pins Packaged Products							
CJ6111-1.8	CJ6111-DAN-1.8	DFNWB1×1-4L	-40 ~ 85°C	RoHS & Green	Level 1 Infinite	Tape and Reel 10000 Units / Reel	Active
CJ6111-2.8	CJ6111-DAN-2.8	DFNWB1×1-4L	-40 ~ 85°C	RoHS & Green	Level 1 Infinite	Tape and Reel 10000 Units / Reel	Active
CJ6111-3.0	CJ6111-DAN-3.0	DFNWB1×1-4L	-40 ~ 85°C	RoHS & Green	Level 1 Infinite	Tape and Reel 10000 Units / Reel	Active
CJ6111-3.3	CJ6111-DAN-3.3	DFNWB1×1-4L	-40 ~ 85°C	RoHS & Green	Level 1 Infinite	Tape and Reel 10000 Units / Reel	Active

5 Orderable Information

MODEL	DEVICE	PACKAGE	OP TEMP	ECO PLAN	MSL	PACKING OPTION	SORT
5 Pins Packaged Products							
CJ6111-1.8	CJ6111-M5N-1.8	SOT-23-5L	-40 ~ 85°C	RoHS & Green	Level 3 168 HR	Tape and Reel 3000 Units / Reel	Active
CJ6111-2.8	CJ6111-M5N-2.8	SOT-23-5L	-40 ~ 85°C	RoHS & Green	Level 3 168 HR	Tape and Reel 3000 Units / Reel	Active
CJ6111-3.0	CJ6111-M5N-3.0	SOT-23-5L	-40 ~ 85°C	RoHS & Green	Level 3 168 HR	Tape and Reel 3000 Units / Reel	Active
CJ6111-3.3	CJ6111-M5N-3.3	SOT-23-5L	-40 ~ 85°C	RoHS & Green	Level 3 168 HR	Tape and Reel 3000 Units / Reel	Active
Customized Products							
Output available from 1.0V to 5.0V	CJ6111-M3N-x.x	SOT-23-3L	-40 ~ 85°C	RoHS & Green	Level 3 168 HR	Tape and Reel 3000 Units / Reel	Customized
	CJ6111-P3N-x.x	SOT-89-3L	-40 ~ 85°C	RoHS & Green	Level 3 168 HR	Tape and Reel 1000 Units / Reel	Customized
	CJ6111-DAN-x.x	DFNWB1×1-4L	-40 ~ 85°C	RoHS & Green	Level 3 168 HR	Tape and Reel 10000 Units / Reel	Customized
	CJ6111-M5N-x.x	SOT-23-5L	-40 ~ 85°C	RoHS & Green	Level 3 168 HR	Tape and Reel 3000 Units / Reel	Customized
Others	-	-	-	-	-	-	Customized

Note:

ECO PLAN: For the RoHS and Green certification standards of this product, please refer to the official report provided by JSCJ.

MSL: Moisture Sensitivity Level. Determined according to JEDEC industry standard classification.

SORT: Specifically defined as follows:

Active: Recommended for new products;

Customized: Products manufactured to meet the specific needs of customers;

Preview: The device has been released and has not been fully mass produced. The sample may or may not be available;

NoRD: It is not recommended to use the device for new design. The device is only produced for the needs of existing customers;

Obsolete: The device has been discontinued.

6 Pin Configuration and Marking Information

6.1 Pin Configuration

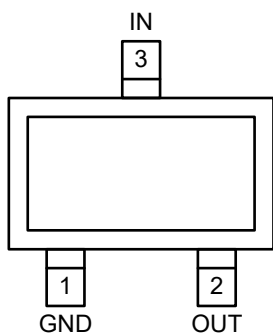

CJ6111-M3N-x.x
SOT-23-3L

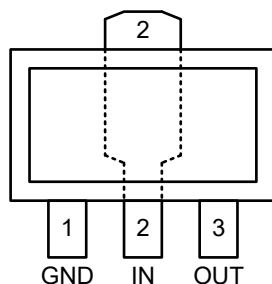

CJ6111-P3N-x.x
SOT-89-3L

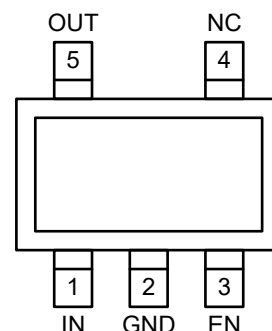

CJ6111-M5N-x.x
SOT-23-5L

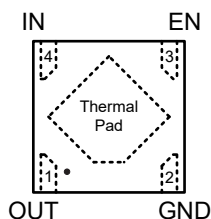

CJ6111-DAN-x.x
DFNWB1x1-4L

(Not to Scale)

6.2 Pin Function

PIN NAME	I / O	CJ6111 Series Pin Function	
			DESCRIPTION
IN	I		Input to the device. Use the recommended value of the input capacitor and place it as close to the input of the device as possible to reduce the impedance of the input supply.
GND	-		Regulator ground.
EN	I		Enable pin. Driving this pin to logic high enables the device; driving this pin to logic low disables the device. If enable functionality is not required, it is recommended to connect this pin to IN.
NC	-		No internal connection. This pin can float, but when this pin is connected to GND, the device has better thermal performance.
OUT	O		Output of the regulator. An output capacitor is required for stability and help device obtain the best transient response. Use the capacitor with the recommended value and place it as close as possible to the output.
Thermal Pad	-		Connect the thermal pad to a large-area ground plane. The thermal pad is internally connected to GND.

6 Pin Configuration and Marking Information

6.3 Marking Information

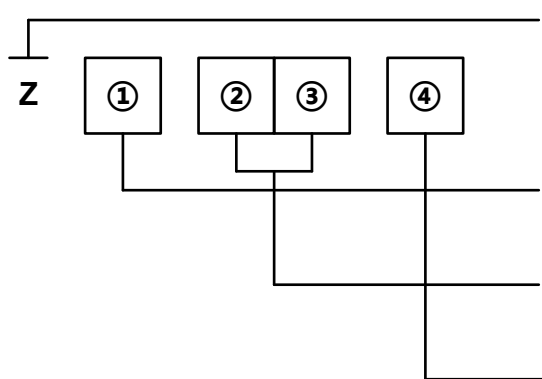
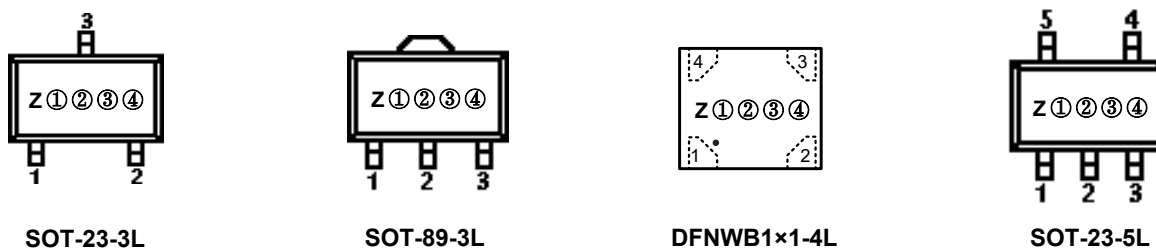

Serial code for CJ6111 series.

Representative output voltage.

D: Fixed output 1.8V
 F: Fixed output 2.8V
 G: Fixed output 3.0V
 H: Fixed output 3.3V
 (Other products are customized)

Code, indicates weekly record information of production.

Code, special pin arrangement sequence.
 (blank): Normal

Figure 5-1. Naming Conventions

Output Voltage	Marking Information for CJ6111 Series			
	3-Pins Packages		4-Pins Package	5-Pins Package
	SOT-23-3L	SOT-89-3L	DFNWB1x1-4L	SOT-23-5L
1.8V	CJ6111-M3N-1.8: ZDXX	-	CJ6111-DAN-1.8: ZDXX	CJ6111-M5N-1.8: ZDXX
2.8V	CJ6111-M3N-2.8: ZFXX	-	CJ6111-DAN-2.8: ZFXX	CJ6111-M5N-2.8: ZFXX
3.0V	CJ6111-M3N-3.0: ZGXX	-	CJ6111-DAN-3.0: ZGXX	CJ6111-M5N-3.0: ZGXX
3.3V	CJ6111-M3N-3.3: ZHXX	-	CJ6111-DAN-3.3: ZHXX	CJ6111-M5N-3.3: ZHXX

7 Specification

7.1 Absolute Maximum Ratings

($T_A = 25^\circ\text{C}$, unless otherwise specified)⁽¹⁾

CHARACTERISTIC		SYMBOL	VALUE	UNIT	
Input voltage range ⁽²⁾		V_{IN}	-0.3 ~ 8	V	
Enable input voltage range ⁽²⁾		V_{EN}	-0.3 ~ $V_{IN} + 0.3$		
Output voltage range ⁽²⁾		V_{OUT}	-0.3 ~ $V_{IN} + 0.3$		
Maximum power dissipation	CJ6111 Series	SOT-23-3L	$P_{D \text{ Max}}$	Internally Limited ⁽³⁾	W
		SOT-89-3L			
		DFNWB1×1-4L			
		SOT-23-5L			
Maximum junction temperature		$T_{J \text{ Max}}$	150	$^\circ\text{C}$	
Storage temperature		T_{stg}	-55 ~ 150	$^\circ\text{C}$	
Soldering temperature & time		T_{solder}	260 $^\circ\text{C}$, 10s	-	

(1) Stresses beyond those listed under *Absolute Maximum Ratings* may cause permanent damage to the device. These are stress ratings only, which do not imply functional operation of the device at these or any other conditions beyond those indicated under *Recommended Operating Conditions*. Exposure to absolute-maximum rated conditions for extended periods may affect device reliability.

(2) All voltages are with respect to network ground terminal.

(3) Refer to *Thermal Information* for details.

7.2 Recommended Operating Conditions

PARAMETER	SYMBOL	MIN.	NOM.	MAX.	UNIT
Input voltage	V_{IN}	2.0	-	6.5	V
Operating junction temperature	T_J	-40	-	125	$^\circ\text{C}$
Operating ambient temperature ⁽⁴⁾	T_A	-40	-	85	$^\circ\text{C}$

(4) It is necessary to ensure that the operating junction temperature of the device does not exceed the rated value of the recommended operating conditions when using the device for design.

7 Specification

7.3 ESD Ratings

ESD RATINGS		SYMBOL	VALUE	UNIT
Electrostatic discharge ⁽⁵⁾	Human body model	$V_{ESD-HBM}$	2000	V
	Machine model	V_{ESD-MM}	400	

(5) ESD testing is conducted in accordance with the relevant specifications formulated by the Joint Electronic Equipment Engineering Commission (JEDEC). The human body model (HBM) electrostatic discharge test is based on the JESD22-114D test standard, using a 100pF capacitor and discharging to each pin of the device through a resistance of 1.5kΩ. The electrostatic discharge test in mechanical model (MM) is based on the JESD22-A115-A test standard and uses a 200pF capacitor to discharge directly to each pin of the device.

7.4 Thermal Information

THERMAL METRIC ⁽⁶⁾	SYMBOL	CJ6111 Series		UNIT
Junction-to-ambient thermal resistance	$R_{\theta JA}$	SOT-23-3L	SOT-89-3L	°C/W
		259.3	TBD ⁽⁷⁾	
		DFNWB1×1-4L	SOT-23-5L	
		222.0	249.6	
Junction-to-case thermal resistance	$R_{\theta JC}$	SOT-23-3L	SOT-89-3L	°C/W
		65.0	TBD ⁽⁷⁾	
		DFNWB1×1-4L	SOT-23-5L	
		114.3	64.1	
Reference maximum power dissipation for continuous operation	$P_{D Ref}$	SOT-23-3L	SOT-89-3L	W
		0.38	TBD ⁽⁷⁾	
		DFNWB1×1-4L	SOT-23-5L	
		0.45	0.42	

(6) Thermal metric is measured in still air with $T_A = 25^{\circ}\text{C}$ and installed on a 1 in² FR-4 board covered with 2 ounces of copper.

(7) Customized products, to be determined.

7 Specification

7.5 Electrical Characteristics

CJ6111 Series ($V_{IN} = V_{OUT} + 1V$, $C_{IN} = 1.0\mu F$, $C_{OUT} = 1.0\mu F$, $T_A = 25^\circ C$, unless otherwise specified)

CHARACTERISTIC	SYMBOL	TEST CONDITIONS		MIN.	TYP. ⁽⁸⁾	MAX.	UNIT
Input voltage	V_{IN}	$T_A = 25^\circ C$		2.0	-	6.5	V
DC output tolerance	-	$T_J = 25^\circ C$, $I_{OUT} = 1mA$		-1	-	1	%
Output current	I_{OUT}	-		-	300	-	mA
Quiescent current	I_Q	$I_{OUT} = 0mA$		-	0.8	1.5	μA
Dropout voltage	$V_{DO}^{(9)}$	$V_{OUT} = 1.8$ to $2.5V$	$I_{OUT} = 100mA$	-	200	-	mV
		$V_{OUT} = 2.6$ to $2.9V$		-	140	-	
		$V_{OUT} = 5.0V$		-	120	-	
Line regulation	$LNR^{(10)}$	$V_{IN} = V_{OUT} + 1V$ to $6.5V$, $I_{OUT} = 10mA$		-	0.02	0.3	% / V
Load regulation	ΔV_{LOAD}	$V_{IN} = V_{OUT} + 1V$, $I_{OUT} = 1$ to $100mA$		-	15	-	mV
		$V_{IN} = V_{OUT} + 1V$, $I_{OUT} = 1$ to $300mA$		-	27	55	
Temperature characteristics	$TR^{(11)}$	$V_{IN} = 5.0V$, $I_{OUT} = 1mA$, $T_A = -40$ to $85^\circ C$		-	15	-	ppm / $^\circ C$
Output current limit	I_{Limit}	-		-	510	-	mA
Shutdown current	I_{SHDN}	EN = GND		-	-	0.2	μA
Power supply rejection ratio	PSRR	$V_{IN} = (V_{OUT} + 1V)_{DC} + 1V_{PPAC}$, $I_{OUT} = 10mA$	$f = 100Hz$	-	65	-	dB
			$f = 1kHz$	-	80	-	
		$V_{IN} = (V_{OUT} + 1V)_{DC} + 1V_{PPAC}$, $I_{OUT} = 100mA$	$f = 100Hz$	-	60	-	
			$f = 1kHz$	-	70	-	
Output noise voltage	V_N	BW = 10 to 100k Hz		-	$25 \times V_{OUT}$	-	μV_{RMS}
EN high	$V_{EN\ High}$	-		1.2	-	V_{IN}	V
EN low	$V_{EN\ Low}$	-		-	-	0.3	V
C_{OUT} auto-discharge resistance	$R_{Discharge}$	$V_{IN} = 5.0V$, $V_{OUT} = 1.5V$, EN = GND		-	500	-	Ω
Thermal shutdown	T_{SD}	-		-	150	-	$^\circ C$
Thermal shutdown hysteresis	ΔT_{SD}	-		-	20	-	$^\circ C$

7 Specification

7.5 Electrical Characteristics (continued)

Note:

(8) Typical numbers are at 25°C and represent the most likely norm.

(9) Test the difference of output voltage and input voltage when input voltage is decreased gradually till output voltage equals to 98% of $V_{OUT\ Normal}$.

(10) The line regulation is calculated by the following formula:

$$LNR = \frac{\Delta V_{OUT}}{V_{OUT} \times \Delta V_{IN}}$$

where, ΔV_{OUT} is the variation of the output voltage, ΔV_{IN} is the variation of the input voltage.

(11) The output voltage temperature characteristics (TR) is calculated by the following formula:

$$TR = \frac{\Delta V_{OUT}}{V_{OUT} \times \Delta T}$$

where, ΔV_{OUT} is the variation of the output voltage, ΔT is the variation of the ambient temperature.

7.6 Typical Characteristics

CJ6111 Series ($V_{OUT} = 3.3V$, $C_{IN} = 1.0\mu F$, $C_{OUT} = 1.0\mu F$, $T_A = 25^\circ C$, unless otherwise specified)

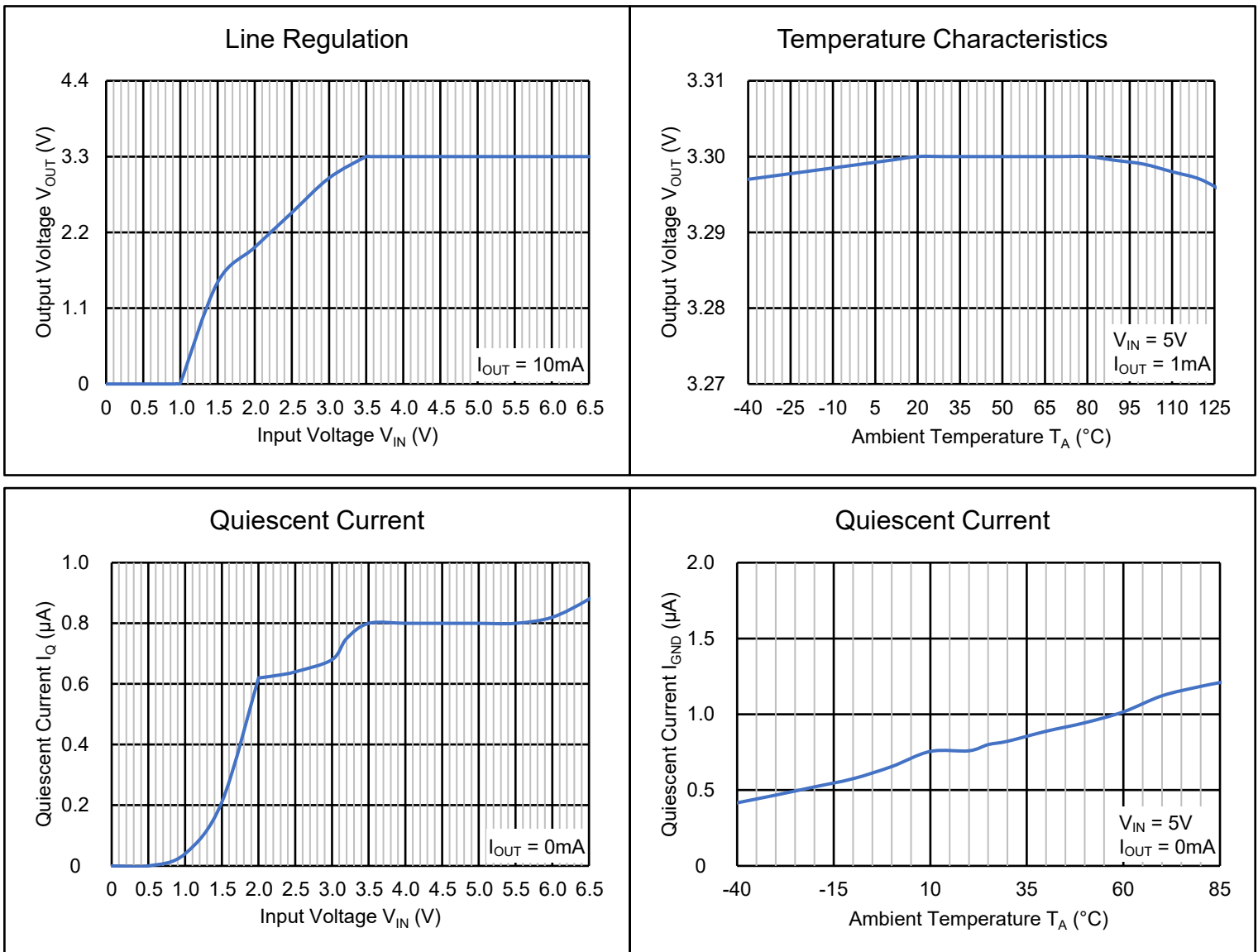

7 Specification

7.6 Typical Characteristics (continued)

CJ6111 Series ($V_{OUT} = 3.3V$, $C_{IN} = 1.0\mu F$, $C_{OUT} = 1.0\mu F$, $T_A = 25^\circ C$, unless otherwise specified)

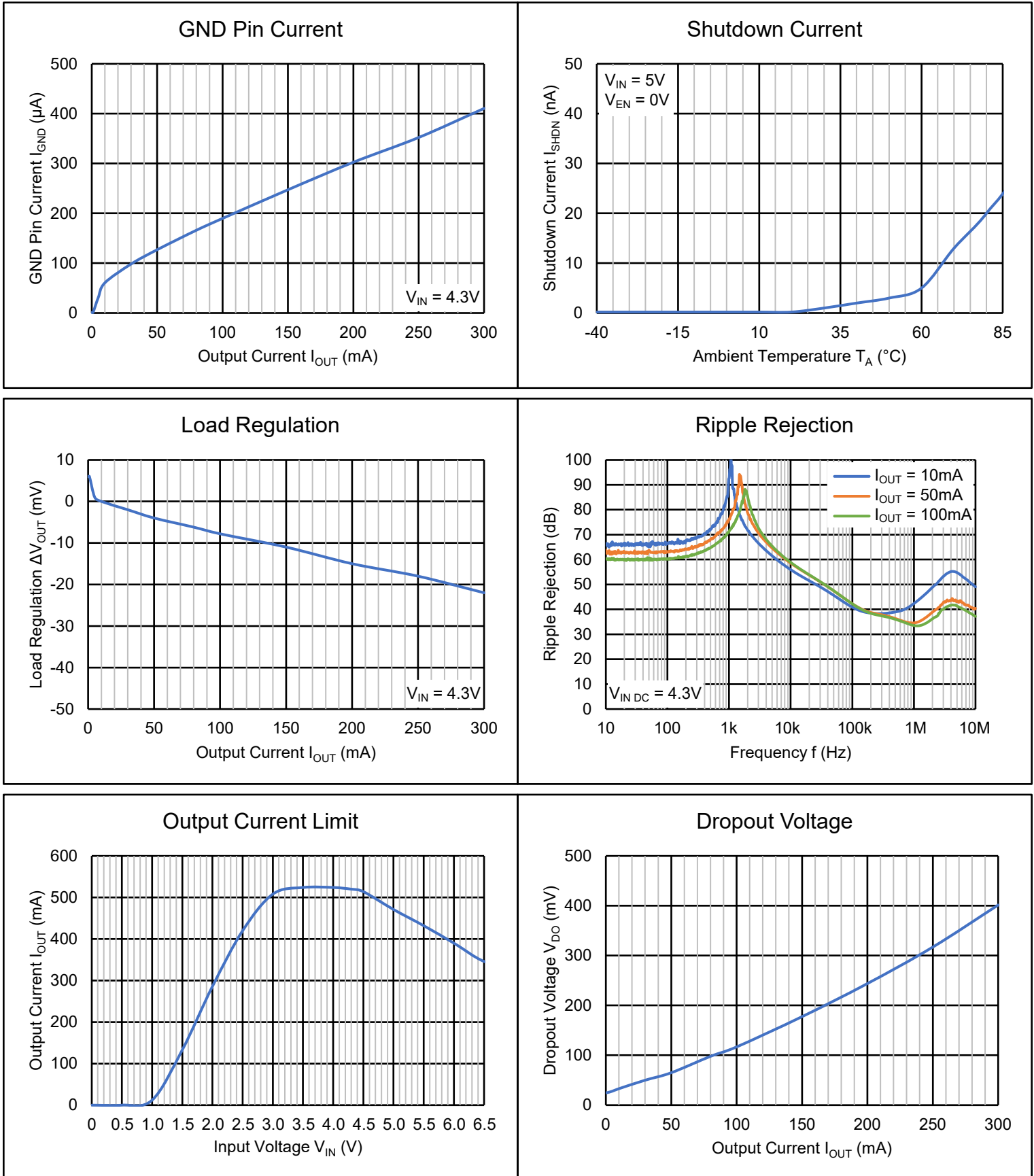

7 Specification

7.6 Typical Characteristics (continued)

CJ6111 Series ($V_{OUT} = 3.3V$, $C_{IN} = 1.0\mu F$, $C_{OUT} = 1.0\mu F$, $T_A = 25^\circ C$, unless otherwise specified)

EN High ($V_{IN} = 4.3V$, $V_{EN} = 0 \sim 4.3V$)

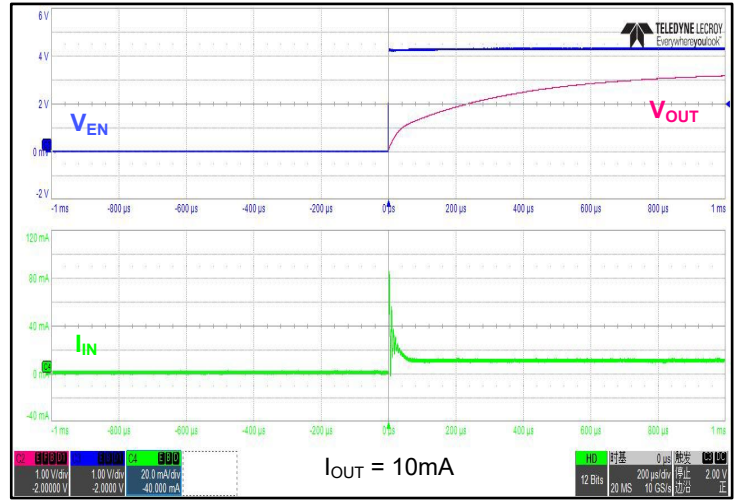
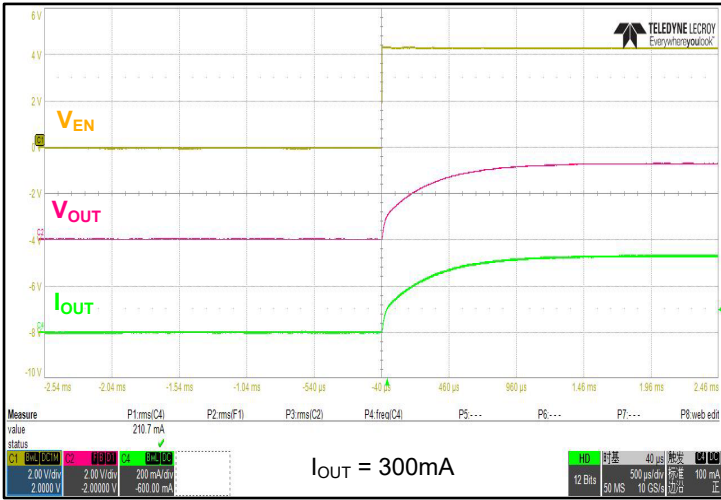

Load Transient ($V_{IN} = 4.3V$, $V_{EN} = V_{IN}$)

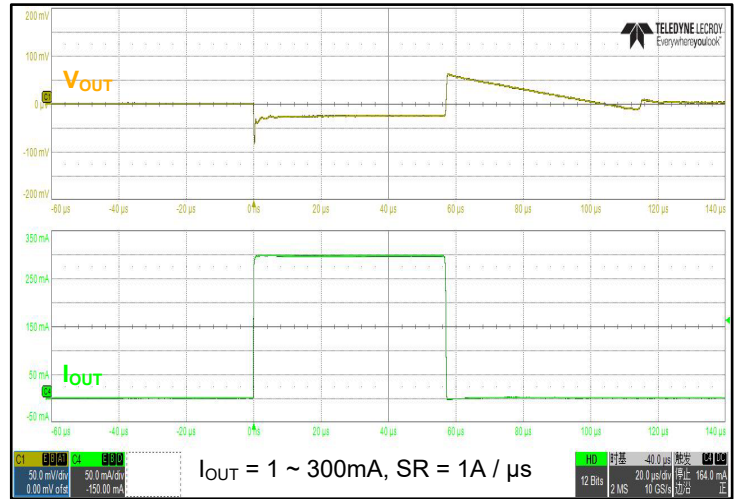
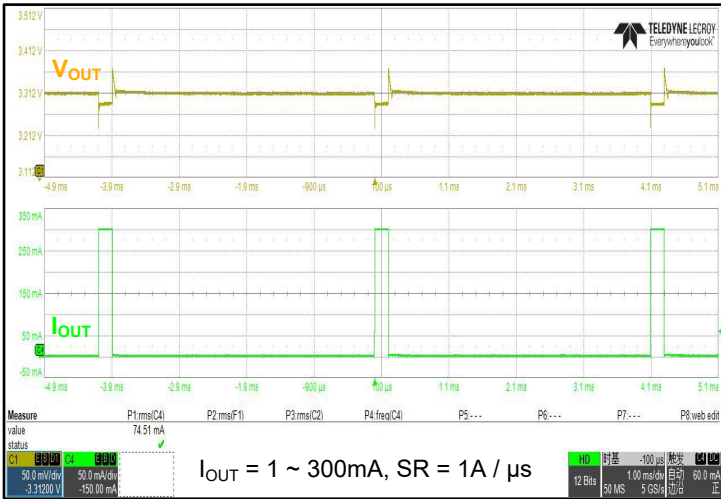

Thermal Shutdown ($V_{IN} = 5.5V$, $I_{OUT} = 400mA$)

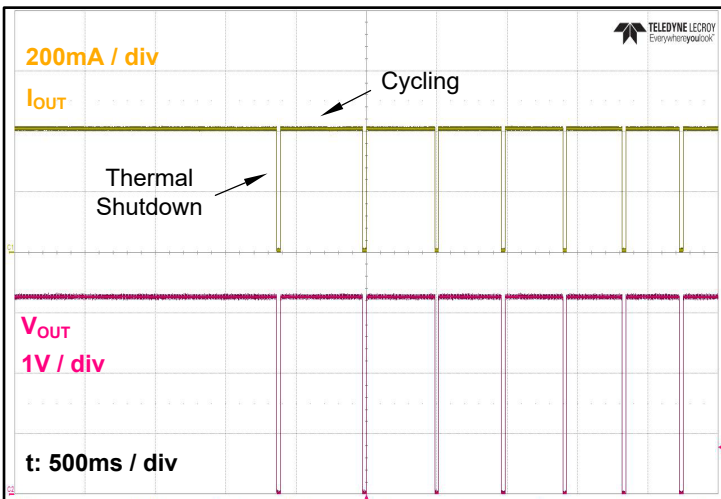

8 Detailed Description

8.1 Description

The CJ6111 series is a group of linear voltage regulators with ultra-low power consumption and low voltage difference. After optimization, it has excellent transient performance. These features make the device ideal for most battery powered applications. This low dropout linear regulator provides built-in current limiting, short circuit protection and thermal shutdown protection functions.

8.2 Functional Block Diagram

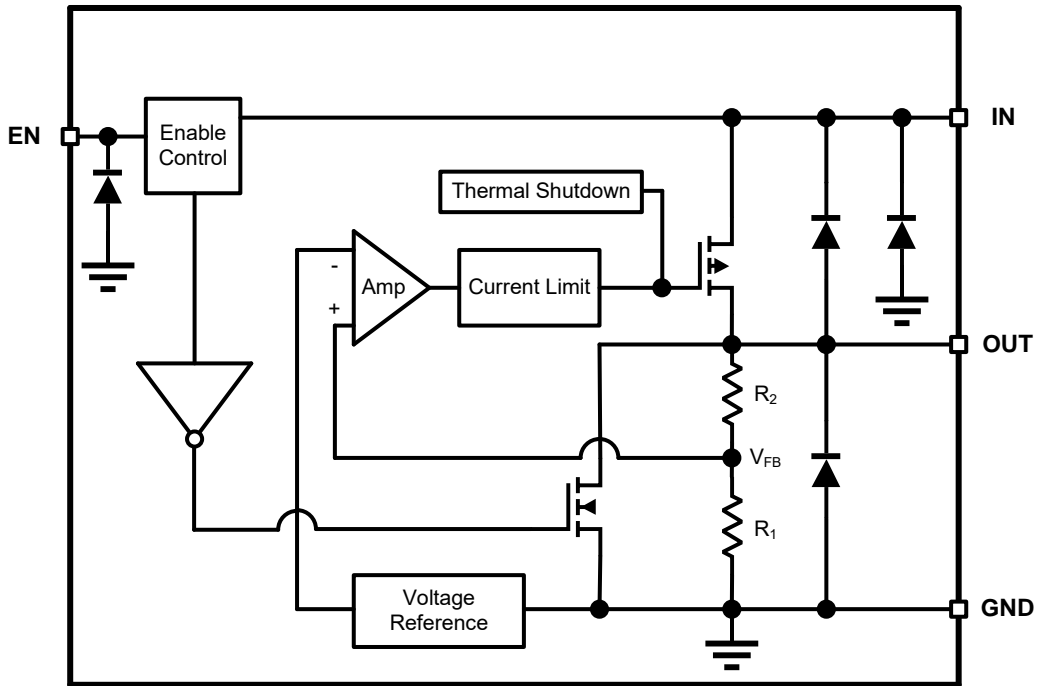

The internal feedback resistors R_1 and R_2 form a voltage divider circuit to compare the V_{FB} input error amplifier with the reference voltage. The internal regulator tube (PMOS) will control its conduction degree through the grid voltage provided by the error amplifier output, which will make the output voltage V_{OUT} not affected by temperature changes or input voltage changes to a certain extent, thus maintaining the stability of the device output voltage.

8 Detailed Description

8.3 Feature Description

Power Supply Input

When the input voltage is lower than the rated range of the data sheet, the device will lose the regulation function of stabilizing the output voltage, that is, it is unable to maintain the output voltage within the rated range. At this time, compared with normal operation, the transient response performance may be seriously degraded.

When the input voltage is higher than the rated range of the data sheet, the device may cause irreversible damage or failure due to exceeding the maximum rated range of electrical stress.

For the rated input voltage of the device, see *Recommended Operating Conditions*.

Output Current

When the circuit design is appropriate, the CJ6111 series can reach the maximum load capacity of up to 300mA. According to the power dissipation of the package and the effective connection thermal resistance with the environment, selecting the appropriate package for the circuit design can make the device emit more heat energy.

Dropout Voltage

Dropout voltage V_{DO} refers to the minimum voltage difference between input and output $V_{IN} - V_{OUT}$ to make the device output voltage reach the rated range at rated current. When the dropout voltage condition required by the device is reached, the internal MOSFET will be fully turned on, at this time, the MOSFET is equivalent to a switch for regulation. The V_{DO} increases with the increase of load current. Since $V_{IN} - V_{OUT}$ must be no less than the V_{DO} , the V_{DO} indirectly specifies the minimum input voltage of devices under different load current conditions. If the $V_{IN} - V_{OUT}$ is less than the V_{DO} , the performance of the device may deteriorate (see *Operation in Dropout Mode* for details).

Low I_Q in Dropout Mode

In most LDOs the I_Q significantly increases when the device is placed into dropout, which is especially true for low I_Q LDOs. The CJ6111 series helps to reduce the battery discharge by detecting when the device is operating in dropout conditions and maintaining a low I_Q .

Thermal Shutdown

The CJ6111 series has thermal shutdown protection mechanism. When the junction temperature T_J of the internal main channel MOSFET exceeds the thermal shutdown threshold temperature T_{SD} , thermal shutdown will be triggered. At this time, the output will be turned off to prevent catastrophic damage to the chip due to accidental heating. When the T_J drops to a certain range of thermal shutdown threshold temperature ΔT_{SD} , the thermal shutdown will be released and the device will return to the normal output. The temperature threshold of device triggering thermal shutdown T_{SD} and temperature range to be lowered to released from thermal shutdown ΔT_{SD} can be found in the *Electrical Characteristics*.

To ensure reliable operation, please limit the junction temperature to the specified range of *Recommended Operating Conditions* in the data sheet. Applications that exceed the recommended temperature range may cause the device to exceed its operating specifications.

Although the internal protection circuit of the device is designed to prevent overall thermal conditions, it is not intended to replace proper power dissipation. Running the device continuously until thermal shutdown or higher than the recommended operating T_J will reduce long-term reliability.

8 Detailed Description

8.3 Feature Description

Built-in Current Limit & Short Circuit Protection

The CJ6111 series has an internal current limiting circuit, which can protect the device by limiting the load current value in case of instantaneous high load current. When the current limiting is triggered, the output voltage is not regulated. If the out pin of the regulator is short circuited, the internal current limiting circuit also will be triggered. When the load current of the device is large, the device will generate more heat due to the increase of power consumption, which may cause the device to turn off its output due to the internal thermal shutdown protection before the current limit is triggered.

In order to ensure the normal operation of current limit, the inductance of input and load shall be minimized. Continuous operation under current limit is not recommended.

Enable Control

The enable pin of the device EN is active at high level. When the voltage of the EN is greater than the EN logic high voltage $V_{EN\ High}$, the device will be enabled and maintain the normal output. When the voltage of the EN is lower than the EN logic low voltage $V_{EN\ Low}$, the internal circuit of the device will be disabled and the output will be turned off the device, the device will be in the standby mode until EN is turned to high level again. The $V_{EN\ High}$ and $V_{EN\ Low}$ can be found in the *Electrical Characteristics*.

Normal startup waveform and startup slope rate control can be ensured when the device starts from any low voltage lower than $V_{EN\ Low}$, but the discharge time of output capacitor must be taken into account. If EN is not required to control the output voltage independently, it is recommended to connect EN pin to IN.

Auto-discharge Function

The device with enable control has an auto-discharge circuit. When the enable control is turned off, the device will be disabled. An internally integrated pull-down MOSFET (see *Functional Block Diagram*) will connect a resistor $R_{Discharge}$ to the ground to release the charge in the output capacitor, thus closing the entire device circuit. The value of $R_{Discharge}$ can be found in the *Electrical Characteristics*. The discharge time of the output capacitor after the device is disabled is determined by the output capacitance C_{OUT} and load resistance R_L in parallel with the $R_{Discharge}$. The time constant τ can be calculated by the following formula:

$$\tau = C \times R_{Discharge} \quad (R_L = 0)$$

$$\tau = C \times \left(\frac{R_L \times R_{Discharge}}{R_L + R_{Discharge}} \right) \quad (R_L \neq 0)$$

The output voltage after discharging through pull-down MOSFET can be calculated by the following formula:

$$V = V_{OUT} \times e^{-\frac{t}{\tau}}$$

$$t = \tau \times \ln\left(\frac{V}{V_{OUT}}\right)$$

Where, V is the output voltage after discharge, V_{OUT} is the output voltage, t is the discharge time, τ is the discharge time constant.

Do not rely on the active discharge circuit to release a large amount of output capacitance after the input power supply crashes, because the reverse current can flow from the output to the input. This reverse current may damage the device. The limiting reverse current shall not exceed 5% of the rated current of the device.

9 Application and Implementation

9.1 Typical Application Circuits

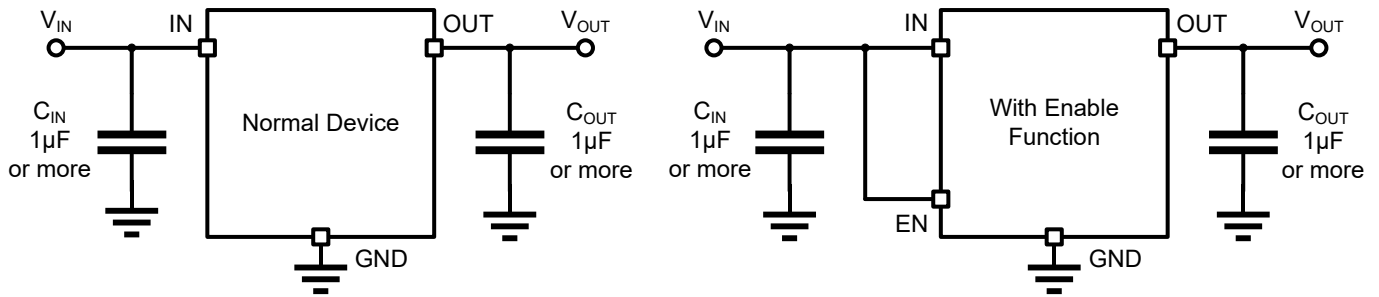

9.2 Application Information

Selection of Bypass Capacitances

For the CJ6111 series, it is recommended to use 1µF input C_{IN} and output C_{OUT} ceramic capacitors.

Type of Capacitors:

Since any leakage of the capacitor will increase the quiescent power consumption of the whole circuit, attention should be paid to selecting capacitors with low leakage. When designing the circuit of portable equipment including CJ6111 series, due to the shortage of tantalum capacitors, it is a good choice to use small size, low equivalent series resistance (ESR) and high RMS current capacity multilayer ceramic capacitors (MLCC) in the DC to DC voltage conversion. The designer must choose the appropriate capacitor type for circuit design: X7R- Ceramic capacitors of X5R- and COG- rated dielectric materials can provide relatively good capacitance stability within the temperature range, Y5V- type capacitors are not recommended because of large changes in capacitance values. However, no matter which type of ceramic capacitor is selected, the effective capacitance may vary with the operating voltage and temperature. The designer must consider the influence of the change of the effective value of capacitance according to the circuit design and application conditions.

Input Capacitors C_{IN} :

It is recommended to use a 1µF capacitor at the input pin of the device, and the position of the input capacitor should be as close to the device input pin as possible.

For the CJ6111 series, the input capacitor is not necessary to maintain the output stability, but it can offset the reactive input source and improve the transient response, input ripple and PSRR performance of the device. It should be noted that although many types of capacitors can be used for input bypass, using ceramic capacitors for input filtering may cause problems. Due to the self resonance and high Q characteristics of some types of ceramic capacitors, under certain starting conditions, applying voltage steps to ceramic capacitors may lead to large current surges (such as directly connecting the input pin of LDO to the power supply), which may cause some energy stored in the parasitic inductance of the power lead. When the stored energy is transferred from these inductors to ceramic capacitors, large voltage spikes may occur in the circuit. These voltage spikes are easily twice the step amplitude of the input voltage, and are likely to bring potential risks to the normal operation and reliability of the device. Therefore, the selection of ceramic capacitors as input capacitors must be careful. Adding 3Ω resistors and X5R- type ceramic capacitors will minimize voltage transients during startup. A higher value capacitor may be necessary if large, fast rise-time load or line transients are anticipated or if the device is located several inches from the input power source.

9 Application and Implementation

9.2 Application Information (continued)

Selection of Bypass Capacitances (continued)

Output Capacitors C_{OUT} :

Recommended $1\mu\text{F}$ output ceramic capacitor to keep the device output stable, and the capacitor position should be as close to the device pin as possible.

For CJ6111 series, the device needs an output capacitor to achieve loop stability. As with any regulator, a larger output capacitance reduces the peaks during a load transient but slows down the response time of the device. The proper capacitor can help to obtain better dynamic performance.

Transient Response

Transient response refers to the change of system output from initial state to stable state under the action of typical signal input. For LDO, the designer should pay attention to the possible impact of linear transient response and load transient response on the system: linear transient response refers to the transient response of output to change when the input voltage changes, while load transient response refers to the transient response of output to change when the output current changes. The specific phenomenon is that the output voltage of the device will have a short spike, especially when the input voltage or output current changes greatly in a short time. This change is not only related to the performance of the chip itself, but also related to the change of output current, change rate and output capacitance.

1. When the output current increases, the output voltage of the device will decrease to a certain extent, and the larger output current will provide a higher current discharge path for the output capacitor, which will affect the peak value generated by the transient spike and reduce the peak value;
2. The output current or input voltage changes relatively slowly, and the output change of the device is relatively small, affecting the spike caused by the change;
3. The use of large input and output capacitors can reduce the spike caused by transient response to a certain extent to improve the transient performance, but large output capacitors can also affect the response time of devices.

Operation in Dropout Mode

The CJ6111 series is internally integrated with a P-MOSFET to achieve low dropout voltage. The voltage difference between the input and the output $V_{IN} - V_{OUT}$ of the device must not be lower than the corresponding dropout voltage V_{DO} to ensure that the output voltage tolerance is within the rated range of the data sheet. The dropout voltage will increase with the increase of load current. When the $V_{IN} - V_{OUT}$ is less than the V_{DO} , the P-MOSFET inside the device is in a linear state, the resistance from the input pin to the output pin is equal to the resistance from the drain to the source of the P-MOSFET, and the device functions like a resistor. When operating in this state, the response time of the error amplifier inside the device will be limited, which will seriously degrade the transient performance of the device, when the external circuit has a transient change, the deviation of the output voltage will become larger than the normal operating state. In addition, the PSRR and noise performance of the device will be worse than that under normal operating conditions.

Power Supply Recommendation

The CJ6111 series is designed to operate within the input power supply voltage range of 2.0V to 6.5V. The input power supply should be well adjusted and have low noise. If the input power supply has high noise, it is recommended to use an additional bypass capacitor at the input to improve the output noise performance of the device. It is recommended to use an input capacitor of $1\mu\text{F}$ or higher to reduce the impedance of the input power supply, especially during transients.

9 Application and Implementation

9.2 Application Information (continued)

Recommended Continuous Operating Areas

As an LDO, the working area of CJ6111 series is limited by dropout voltage, output current, junction temperature and input voltage under continuous working condition. The recommended areas for continuous operation are shown in Figure 9-1:

- A. The LDO input and output voltage difference $V_{IN} - V_{OUT}$ must meet the dropout voltage V_{DO} conditions. See *Dropout Voltage* for more details.
- B. Rated output current range I_{Rated} .
- C. The actual junction temperature T_J of LDO shall not exceed the rated junction temperature. The product of voltage difference and current at both ends of LDO is power consumption, which determines the actual working junction temperature of LDO, so the curve is not linear.

In addition, the working area of CJ6111 series is limited by the rated $V_{IN MIN}$ and $V_{IN MAX}$.

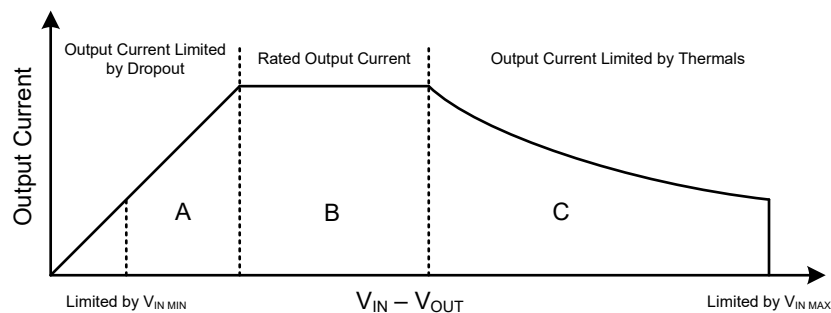

Figure 9-1. Region Description for Continuous Operation

9.3 Layout Guidelines

When designing the circuit including CJ6111 series, the following matters should be noted:

- Place the input and output capacitors as close to the pins of the device as possible;
- The device is connected by copper plane and the heat sink (or back pad) of the device is fully welded with PCB to obtain better heat dissipation performance and lower on resistance;
- Heat sink holes are placed around the device to help the circuit dissipate more heat energy. However, attention should be paid to the position of the heat sink holes to prevent the solder (or solder paste) on the IC pad from being absorbed by the heat sink holes and being damaged during welding.

NOTE

The application information in this section is not part of the data sheet component specification, and JSCJ makes no commitment or statement to guarantee its accuracy or completeness. Customers are responsible for determining the rationality of corresponding components in their circuit design and making tests and verifications to ensure the normal realization of their circuit design.

10 Mechanical Information

10.1 SOT-23-3L Mechanical Information

SOT-23-3L Outline Dimensions

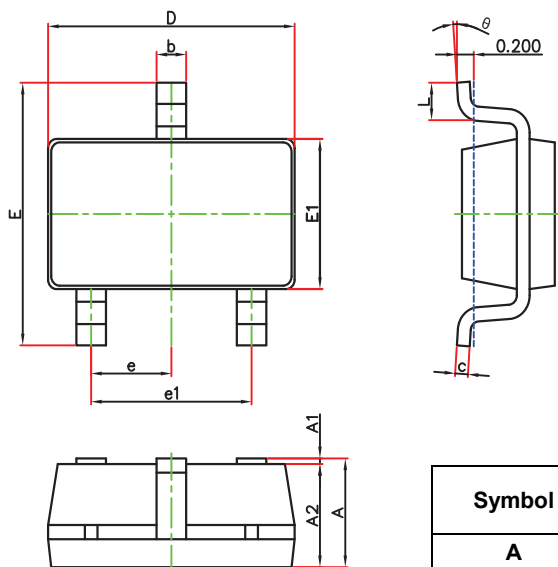

Symbol	Dimensions In Millimeters		Dimensions In Inches	
	Min.	Max.	Min.	Max.
A	1.050	1.250	0.041	0.049
A1	0.000	0.100	0.000	0.004
A2	1.050	1.150	0.041	0.045
b	0.300	0.500	0.012	0.020
c	0.100	0.200	0.004	0.008
D	2.820	3.020	0.111	0.119
E	2.650	2.950	0.104	0.116
E1	1.500	1.700	0.059	0.067
e	0.950(BSC)		0.037(BSC)	
e1	1.800	2.000	0.071	0.079
L	0.300	0.600	0.012	0.024
θ	0°	8°	0°	8°

SOT-23-3L Suggested Pad Layout

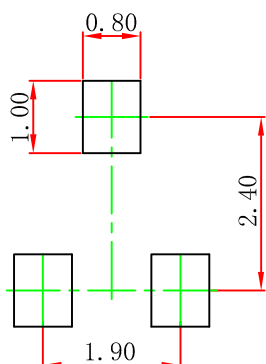

Note:

1. Controlling dimension: in millimeters.
2. General tolerance: ±0.05mm.
3. The pad layout is for reference purpose only.

10 Mechanical Information

10.2 SOT-89-3L Mechanical Information

SOT-89-3L Outline Dimensions

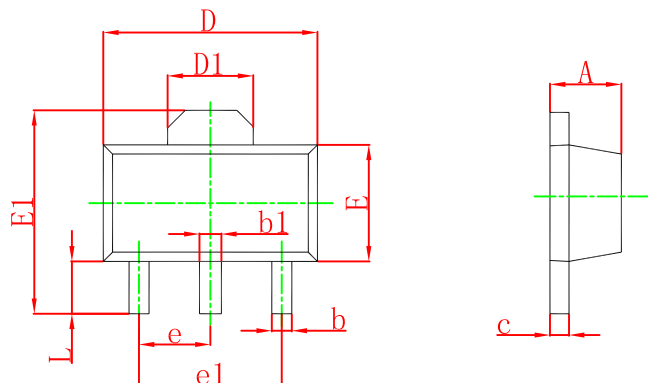

Symbol	Dimensions In Millimeters		Dimensions In Inches	
	Min.	Max.	Min.	Max.
A	1.400	1.600	0.055	0.063
b	0.320	0.520	0.013	0.197
b1	0.400	0.580	0.016	0.023
c	0.350	0.440	0.014	0.017
D	4.400	4.600	0.173	0.181
D1	1.550 REF		0.061 REF	
E	2.300	2.600	0.091	0.102
E1	3.940	4.250	0.155	0.167
e	1.500 TYP		0.060 TYP	
e1	3.000 TYP		0.118 TYP	
L	0.900	1.200	0.035	0.047

SOT-89-3L Suggested Pad Layout

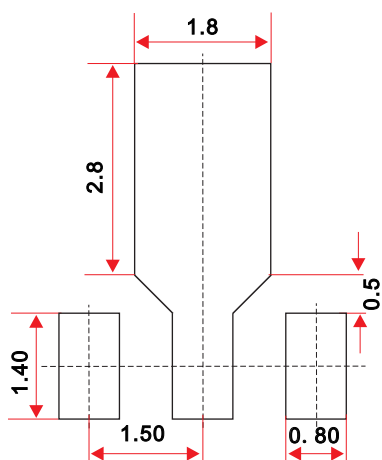

Note:

1. Controlling dimension: in millimeters.
2. General tolerance: $\pm 0.05\text{mm}$.
3. The pad layout is for reference purpose only.

10 Mechanical Information

10.3 DFNWB1×1-4L Mechanical Information

DFNWB1×1-4L Outline Dimensions

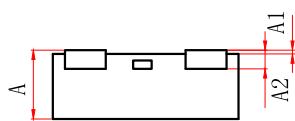
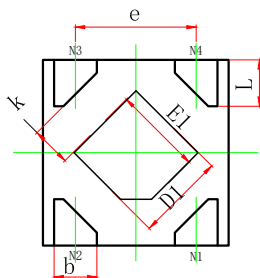
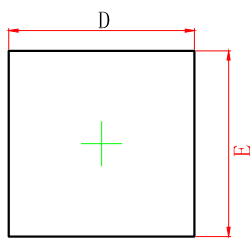

Symbol	Dimensions In Millimeters		Dimensions In Inches	
	Min.	Max.	Min.	Max.
A	0.320	0.400	0.013	0.016
A1	0.000	0.050	0.000	0.002
A2	0.100 REF.		0.004 REF.	
D	0.950	1.050	0.037	0.041
E	0.950	1.050	0.037	0.041
D1	0.430	0.530	0.017	0.021
E1	0.430	0.530	0.017	0.021
k	0.150MIN.		0.006MIN.	
b	0.180	0.280	0.007	0.011
e	0.650TYP.		0.026TYP.	
L	0.200	0.300	0.008	0.012

DFNWB1×1-4L Suggested Pad Layout

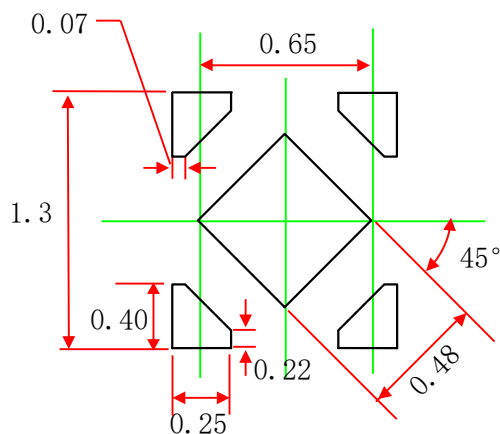

Note:

1. Controlling dimension: in millimeters.
2. General tolerance: $\pm 0.05\text{mm}$.
3. The pad layout is for reference purpose only.

10 Mechanical Information

10.4 SOT-23-5L Mechanical Information

SOT-23-5L Outline Dimensions

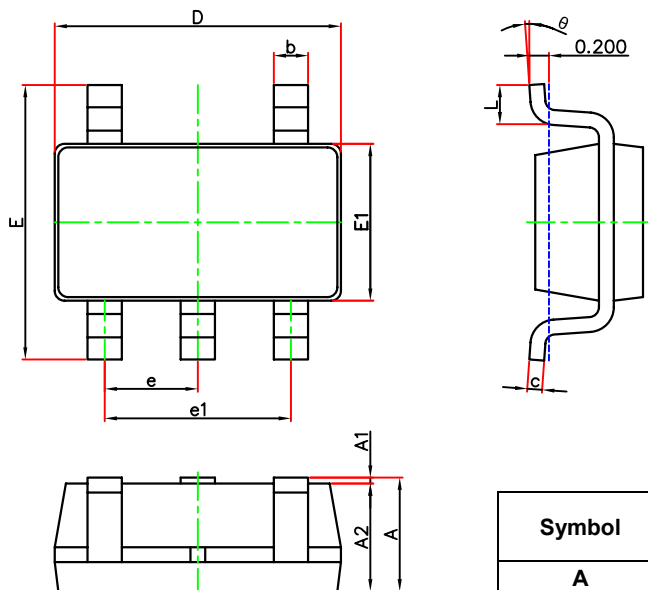

Symbol	Dimensions In Millimeters		Dimensions In Inches	
	Min.	Max.	Min.	Max.
A	1.050	1.250	0.041	0.049
A1	0.000	0.100	0.000	0.004
A2	1.050	1.150	0.041	0.045
b	0.300	0.500	0.012	0.020
c	0.100	0.200	0.004	0.008
D	2.820	3.020	0.111	0.119
E	2.650	2.950	0.104	0.116
E1	1.500	1.700	0.059	0.067
e	0.950(BSC)		0.037(BSC)	
e1	1.800	2.000	0.071	0.079
L	0.300	0.600	0.012	0.024
theta	0°	8°	0°	8°

SOT-23-5L Suggested Pad Layout

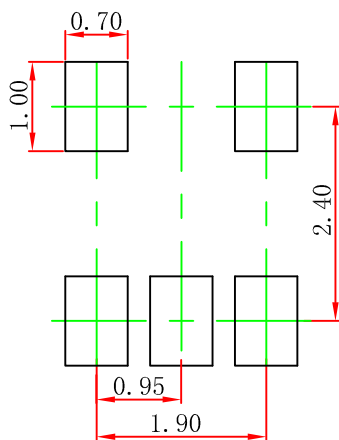

Note:

1. Controlling dimension: in millimeters.
2. General tolerance: ±0.05mm.
3. The pad layout is for reference purpose only.

11 Packaging Information

11.1 SOT-23-3L Tape and Reel Information

SOT-23-3L Embossed Carrier Tape

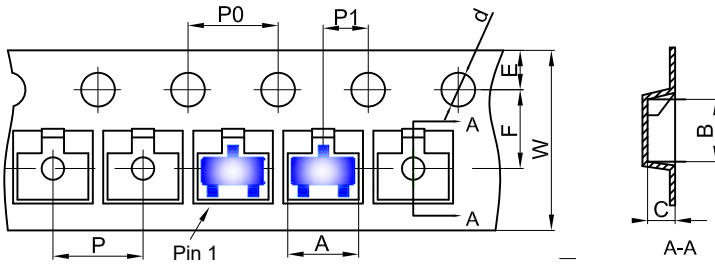

Packaging Description:

SOT-23-3L parts are shipped in tape. The carrier tape is made from a dissipative (carbon filled) polycarbonate resin. The cover tape is a multilayer film (Heat Activated Adhesive in nature) primarily composed of polyester film, adhesive layer, sealant, and anti-static sprayed agent. These reeled parts in standard option are shipped with 3,000 units per 7" or 18.0cm diameter reel. The reels are clear in color and is made of polystyrene plastic (anti-static coated).

Dimensions are in millimeter										
Pkg type	A	B	C	d	E	F	P0	P	P1	W
SOT-23-3L	3.18	3.28	1.32	Ø1.50	1.75	3.50	4.00	4.00	2.00	8.00

SOT-23-3L Tape Leader and Trailer

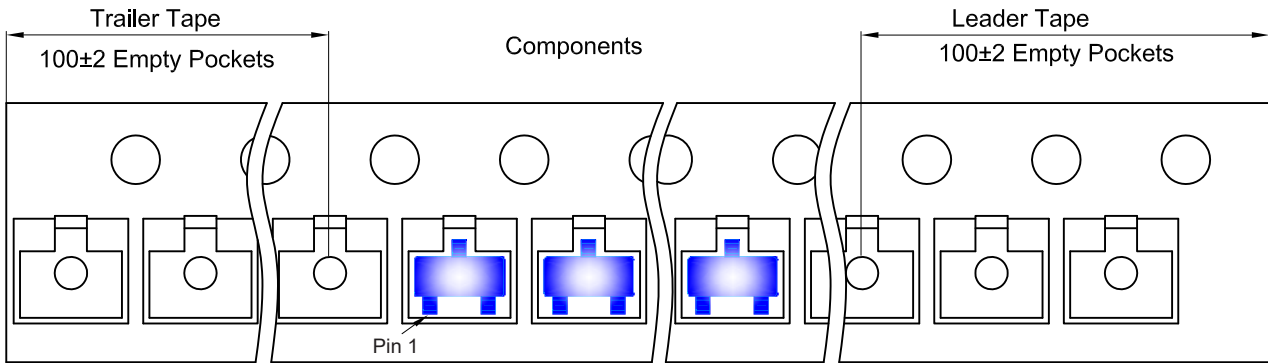

SOT-23-3L Reel

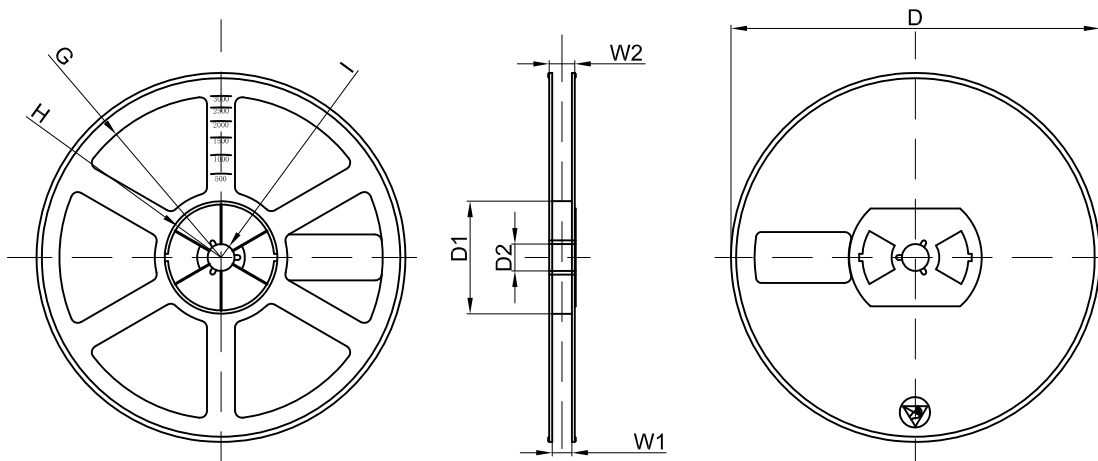

Dimensions are in millimeter								
Reel Option	D	D1	D2	G	H	I	W1	W2
7"Dia	Ø180.00	60.00	13.00	R78.00	R25.60	R6.50	9.50	13.10

REEL	Reel Size	Box	Box Size(mm)	Carton	Carton Size(mm)	G.W.(kg)
3000 pcs	7 inch	30,000 pcs	203×203×195	120,000 pcs	438×438×220	

11 Packaging Information

11.2 SOT-89-3L Tape and Reel Information

SOT-89-3L Embossed Carrier Tape

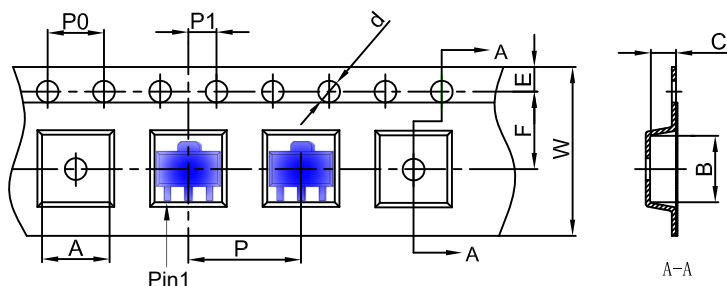

Packaging Description:
 SOT-89-3L parts are shipped in tape. The carrier tape is made from a dissipative (carbon filled) polycarbonate resin. The cover tape is a multilayer film (Heat Activated Adhesive in nature) primarily composed of polyester film, adhesive layer, sealant, and anti-static sprayed agent. These reeled parts in standard option are shipped with 1,000 units per 7" or 18.0 cm diameter reel. The reels are clear in color and is made of polystyrene plastic (anti-static coated).

Dimensions are in millimeter										
Pkg type	A	B	C	d	E	F	P0	P	P1	W
SOT-89-3L	4.85	4.45	1.85	Ø1.50	1.75	5.50	4.00	8.00	2.00	12.00

SOT-89-3L Tape Leader and Trailer

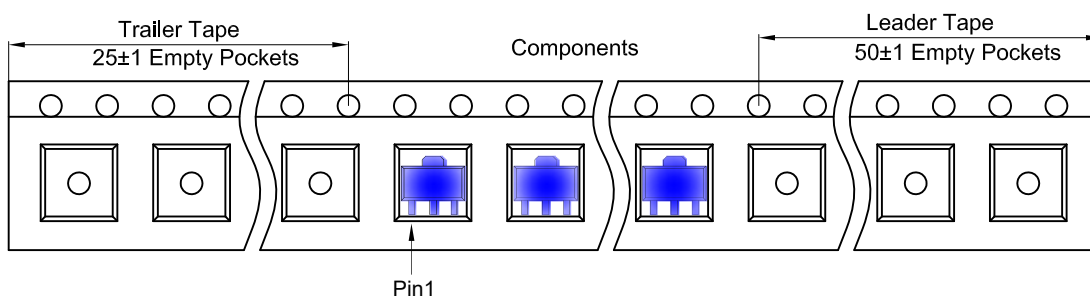

SOT-89-3L Reel

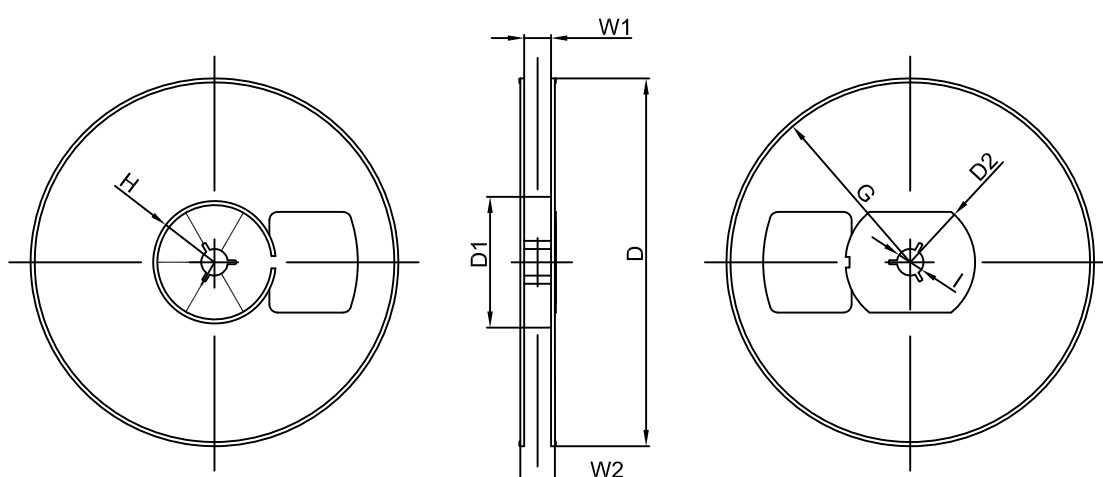

Dimensions are in millimeter								
Reel Option	D	D1	D2	G	H	I	W1	W2
7" Dia	Ø180.00	60.00	R32.00	R86.50	R30.00	Ø13.00	13.20	16.50

REEL	Reel Size	Box	Box Size(mm)	Carton	Carton Size(mm)	G.W.(kg)
1000 pcs	7 inch	10,000 pcs	203×203×195	40,000 pcs	438×438×220	

11 Packaging Information

11.3 DFNWB1×1-4L Tape and Reel Information

DFNWB1×1-4L Embossed Carrier Tape

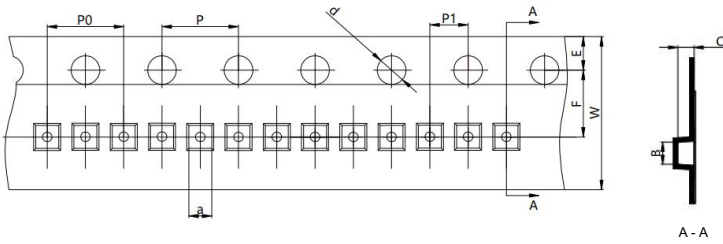

Packaging Description:

DFNWB1×1-4L parts are shipped in tape. The carrier tape is made from a dissipative (carbon filled) polycarbonate resin. The cover tape is a multilayer film (Heat Activated Adhesive in nature) primarily composed of polyester film, adhesive layer, sealant, and anti-static sprayed agent. These reeled parts in standard option are shipped with 3,000 units per 7" or 18.0cm diameter reel. The reels are clear in color and is made of polystyrene plastic (anti-static coated).

Dimensions are in millimeter										
Pkg type	a	B	C	d	E	F	P0	P	P1	W
DFNWB1×1-4L	1.12	1.13	0.50	1.55	1.75	3.5	4.00	4.00	2.00	8.00

DFNWB1×1-4L Tape Leader and Trailer

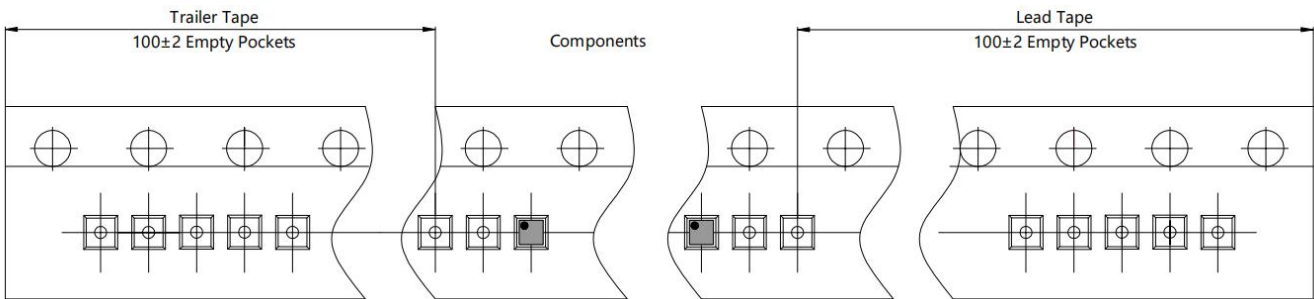

DFNWB1×1-4L Reel

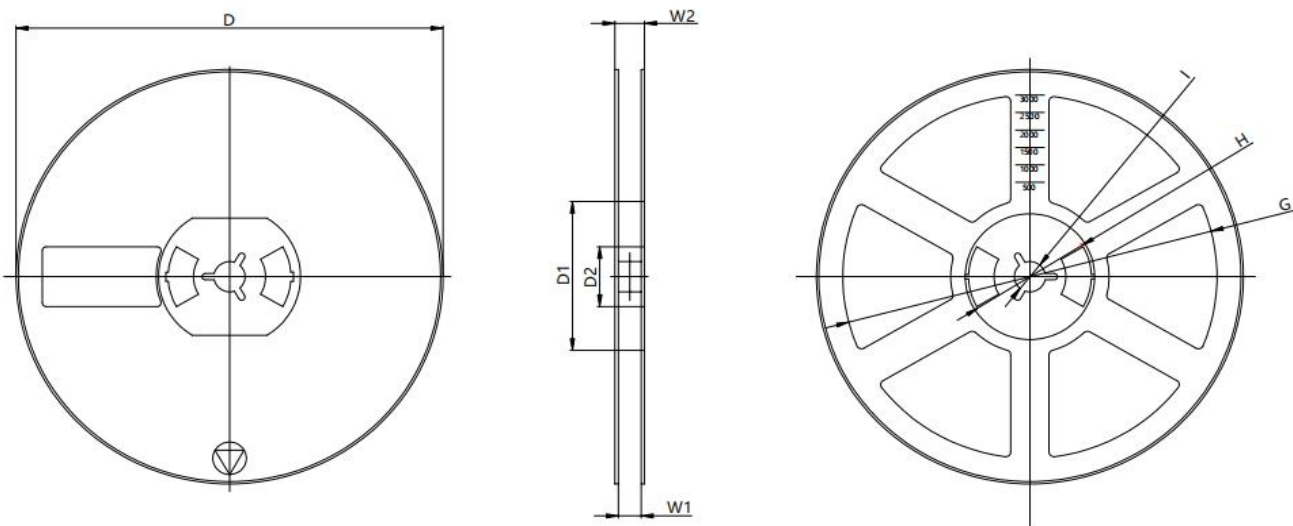

Dimensions are in millimeter								
Reel Option	D	D1	D2	G	H	I	W1	W2
7" Dia	∅ 178.00	54.5	13.5	R78.0	R25.6	R6.75	9.6	12.3

REEL	Reel Size	Box	Box Size(mm)	Carton	Carton Size(mm)	G.W.(kg)
10,000 pcs	7 inch	100,000pcs	210×208×205	400,000 pcs	440×440×230	

11 Packaging Information

11.4 SOT-23-5L Tape and Reel Information

SOT-23-5L Tape and Reel Information

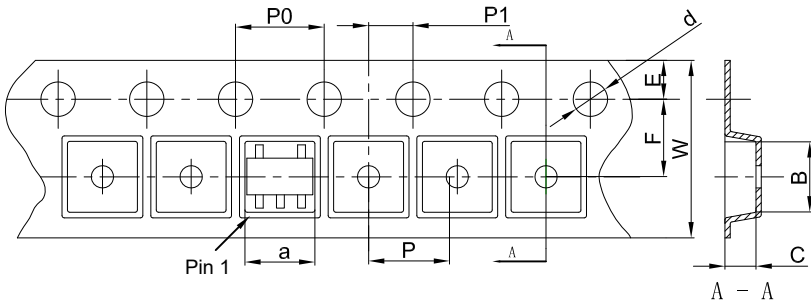

Packaging Description:

SOT-23-5L parts are shipped in tape. The carrier tape is made from a dissipative (carbon filled) polycarbonate resin. The cover tape is a multilayer film (Heat Activated Adhesive in nature) primarily composed of polyester film, adhesive layer, sealant, and anti-static sprayed agent. These reeled parts in standard option are shipped with 3,000 units per 7" or 18.0cm diameter reel. The reels are clear in color and is made of polystyrene plastic (anti-static coated).

Dimensions are in millimeter										
Pkg type	a	B	C	d	E	F	P0	P	P1	W
SOT-23-5L	3.23	3.17	1.37	Ø1.55	1.75	3.50	4.00	4.00	2.00	8.00

SOT-23-5L Tape Leader and Trailer

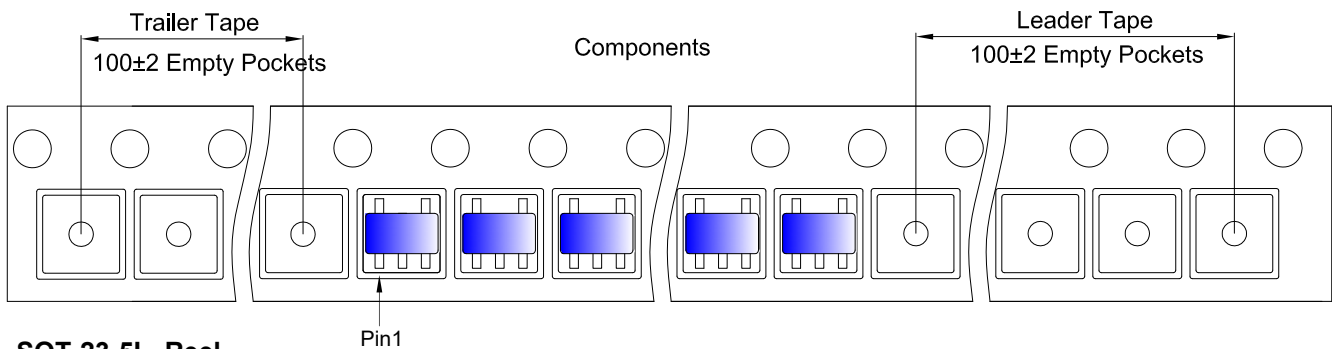

SOT-23-5L Reel

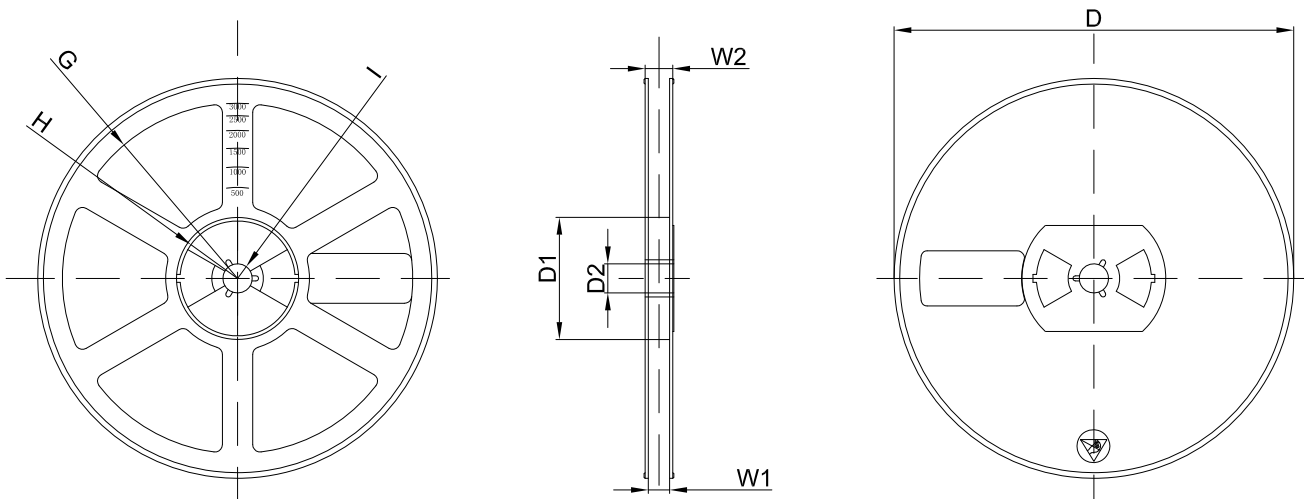

Dimensions are in millimeter								
Reel Option	D	D1	D2	G	H	I	W1	W2
7" Dia	Ø180.00	60.00	13.00	R78.00	R25.60	R6.50	9.50	13.10

REEL	Reel Size	Box	Box Size(mm)	Carton	Carton Size(mm)	G.W.(kg)
3000 pcs	7 inch	30,000 pcs	203×203×195	120,000 pcs	438×438×220	

12 Notes and Revision History

12.1 Associated Product Family and Others

To view other products of the same type or IC products of other types, click the official website of JSCJ -- <https://www.jscj-elec.com> for more details.

12.2 Notes

Electrostatic Discharge Caution



This IC may be damaged by ESD. Relevant personnel shall comply with correct installation and use specifications to avoid ESD damage to the IC. If appropriate measures are not taken to prevent ESD damage, the hazards caused by ESD include but are not limited to degradation of integrated circuit performance or complete damage of integrated circuit. For some precision integrated circuits, a very small parameter change may cause the whole device to be inconsistent with its published specifications.

12.3 Revision History

December, 2023: changed from rev - 1.1 to rev - 1.2:

- Page 1, Features, adjusted the output voltage tolerance from $\pm 2\%$ to $\pm 1\%$;
- Page 8, Electrical Characteristics, adjusted the output voltage tolerance from $\pm 2\%$ to $\pm 1\%$.

December, 2023: changed from rev -1.0 to rev - 1.1:

- Page 3, Orderable Information, added customized product models;
- Page 12, Functional Block Diagram, removed the diode between IN and EN.

October, 2023: released CJ6111 series rev - 1.0.

DISCLAIMER

IMPORTANT NOTICE, PLEASE READ CAREFULLY

The information in this data sheet is intended to describe the operation and characteristics of our products. JSCJ has the right to make any modification, enhancement, improvement, correction or other changes to any content in this data sheet, including but not limited to specification parameters, circuit design and application information, without prior notice.

Any person who purchases or uses JSCJ products for design shall: 1. Select products suitable for circuit application and design; 2. Design, verify and test the rationality of circuit design; 3. Procedures to ensure that the design complies with relevant laws and regulations and the requirements of such laws and regulations. JSCJ makes no warranty or representation as to the accuracy or completeness of the information contained in this data sheet and assumes no responsibility for the application or use of any of the products described in this data sheet.

Without the written consent of JSCJ, this product shall not be used in occasions requiring high quality or high reliability, including but not limited to the following occasions: medical equipment, military facilities and aerospace. JSCJ shall not be responsible for casualties or property losses caused by abnormal use or application of this product.

Official Website: www.jscj-elec.com

Copyright © JIANGSU CHANGJING ELECTRONICS TECHNOLOGY CO., LTD.