

EL 2820

2820-UR3501H-AM

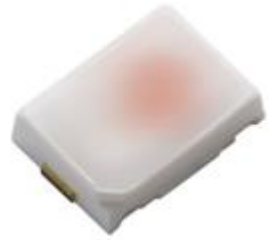

Features

- Package : SMD package
- Color : Red
- Typ. Luminous Flux : 70 lm @ 350mA
- Viewing angle : 120°
- ESD : 2KV
- MSL : 2
- Qualified AEC-Q102
- Compliance with RoHS and REACH
- Compliance Halogen Free .(Br <900 ppm ,Cl <900 ppm , Br+Cl < 1500 ppm)

Applications

- Automotive exterior lighting
- Stop and tail lamp

Contents

1.	CHARACTERISTICS	3
2.	ABSOLUTE MAXIMUM RATINGS	3
3.	MECHANICAL DIMENSION	4
4.	RECOMMENDED SOLDERING PAD	4
5.	BINNING INFORMATION	5
6.	CHARACTERISTICS GRAPH	7
7.	PART NUMBER	12
8.	ORDERING INFORMATION	13
9.	REFLOW SOLDERING PROFILE	14
10.	PACKAGING INFORMATION	15
11.	PRECAUTION FOR USE	17

1. Characteristics

Parameter	Symbol	Min.	Typ.	Max.	Unit	Condition	
Forward Current	I_F	50	350	500	mA	---	
Luminous Flux	I_V	52	70	90	lm	$I_F=350\text{mA}$	
Forward Voltage	V_F	1.7	2.3	2.75	V	$I_F=350\text{mA}$	
Viewing Angle	φ	---	120	---	deg	$I_F=350\text{mA}$	
Dominant Wavelength	λ_d	612	614	627	nm	$I_F=350\text{mA}$	
Thermal Resistance (Junction to Solder)	Real	$R_{th\ JS\ real}$	---	12.8	16.2	K/W	$I_F=350\text{mA}$
	Electrical	$R_{th\ JS\ el}$	---	---	13		

Notes:

1. Luminous flux measurement tolerance: $\pm 8\%$.
2. The data of luminous flux measured at thermal pad= 25°C
3. Forward voltage measurement tolerance: $\pm 0.05\text{V}$
4. Tolerance of Dominant Wavelength : $\pm 1\text{nm}$.

2. Absolute Maximum Ratings

Parameter	Symbol	Ratings	Unit
Power Dissipation	P_d	1375	mW
Forward Current	I_F	500	mA
Surge Current ($t \leq 10\ \mu\text{s}$; $D=0.005$; $T_s=25^\circ\text{C}$)	I_{FM}	1000	mA
Reverse Voltage	V_R	Not designed for reverse operation	V
Junction Temperature	T_J	150	$^\circ\text{C}$
Operating Temperature	T_{opr}	-40 ~ +125	$^\circ\text{C}$
Storage Temperature	T_{stg}	-40 ~ +125	$^\circ\text{C}$
ESD Sensitivity ($R=1.5\text{k}\Omega$, $C=100\text{pF}$)	ESD_{HBM}	2	kV
Soldering Temperature	Reflow	260 $^\circ\text{C}$ for 30sec	$^\circ\text{C}$

3. Mechanical Dimension

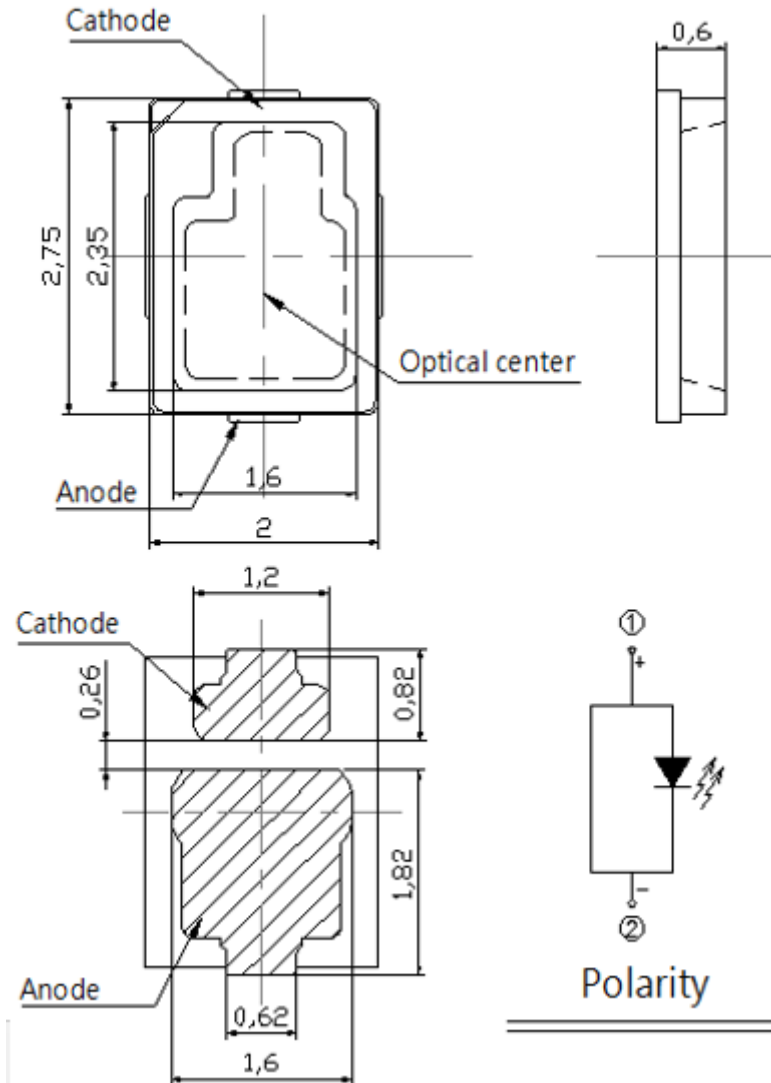

Notes:

- 1. Dimensions are in millimeters.
- 2. Tolerances unless mentioned are ± 0.1 mm.

4. Recommended Soldering Pad

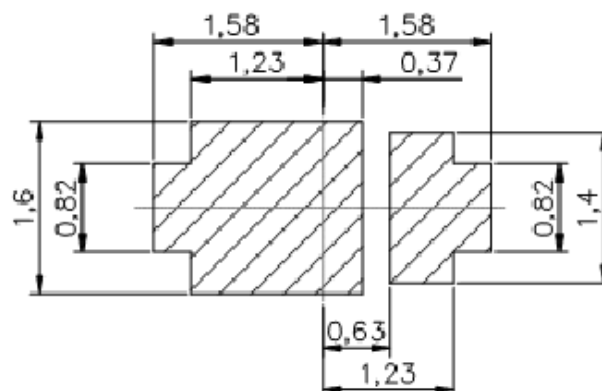

5. Binning Information

Luminous Flux Bins

Group Bin	Minimum Photometric Flux (lm)	Maximum Photometric Flux (lm)
F5	52	60
F6	60	70
F7	70	80
F8	80	90

Notes:

1. Luminous flux measurement tolerance: $\pm 8\%$
2. Test current: Typical forward current
3. Current pulse time: 25ms

Forward Voltage Bins

Bin code	Min Forward Voltage (v)	Max Forward Voltage (v)
1720	1.75	2.00
2022	2.00	2.25
2225	2.25	2.50
2527	2.50	2.75

Notes:

1. Forward voltage measurement tolerance: $\pm 0.05V$.

Dominant Wavelength Bins

Group Bin	Minimum Dominant Wavelength (nm)	Maximum Dominant Wavelength (nm)
1215	612	615
1518	615	618
1821	618	621
2124	621	624
2427	624	627

Notes:

1. Dominant wavelength measurement tolerance: ± 1 nm

6. Characteristics Graph

Wavelength Characteristics Relative Spectral Distribution @ Ts = 25°C, IF=350mA

$$\Phi_v / \Phi_v (Max.) = f(\lambda)$$

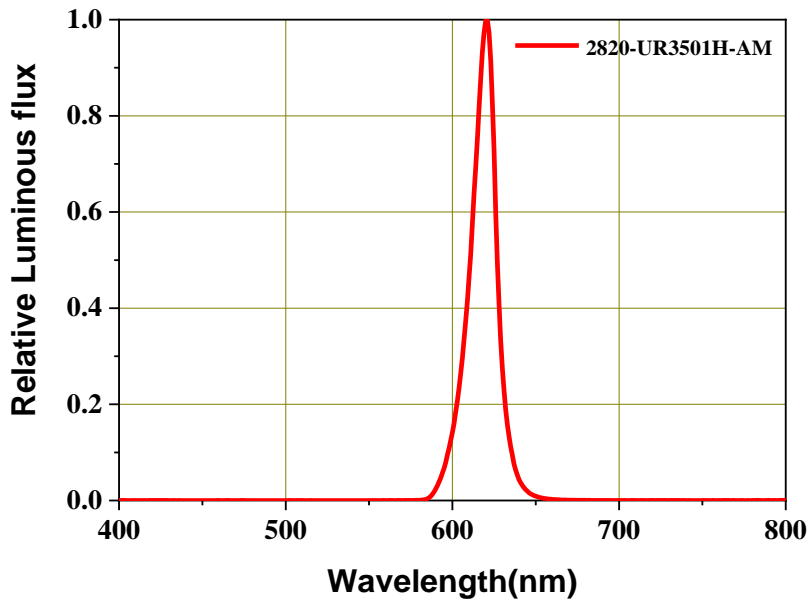

Typical Diagram Characteristics of Radiation

$$\Phi_v / \Phi_v (0^\circ) = f(\varphi)$$

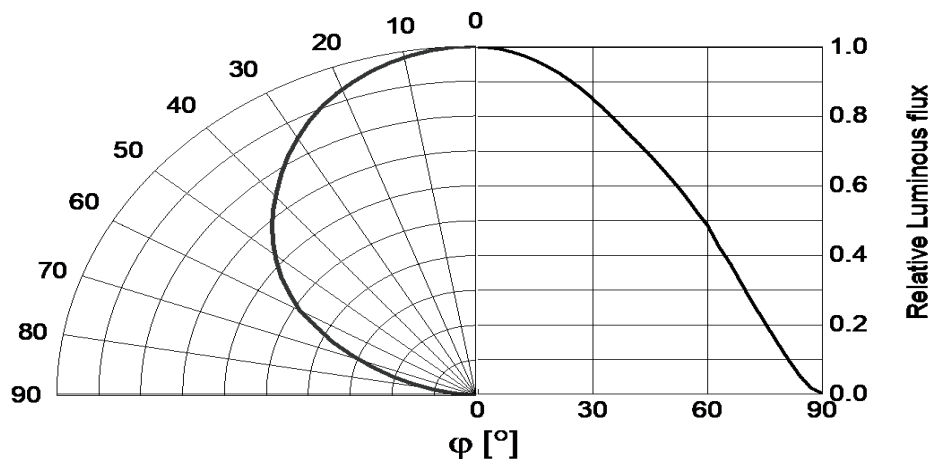

Notes:

1. φ is the off axis angle from lamp centerline where the luminous intensity is 1/2 of the peak value.
2. View angle tolerance is $\pm 5^\circ$.

Forward Current vs. Forward Voltage @ Ts = 25°C

$$I_F = f(V_F)$$

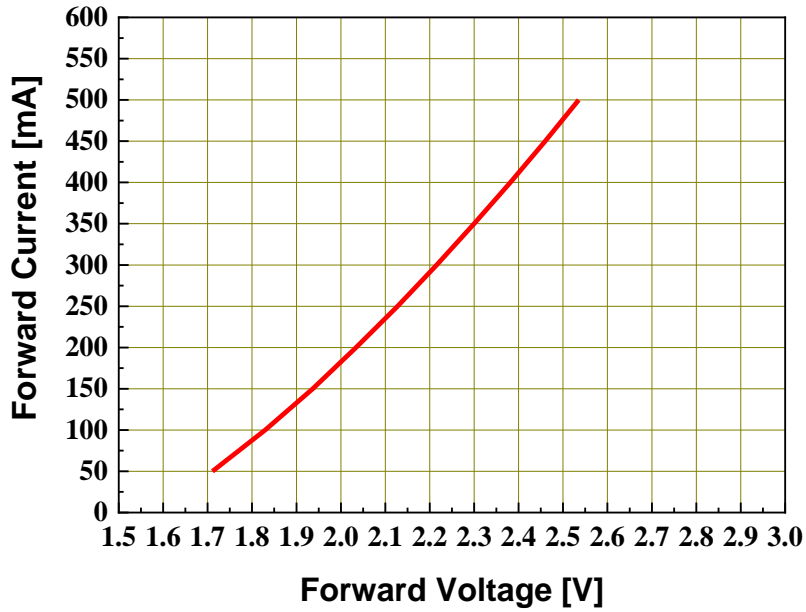

Relative Luminous Flux vs. Forward Current @ Ts = 25°C

$$\Phi_V / \Phi_V(350mA) = f(I_F)$$

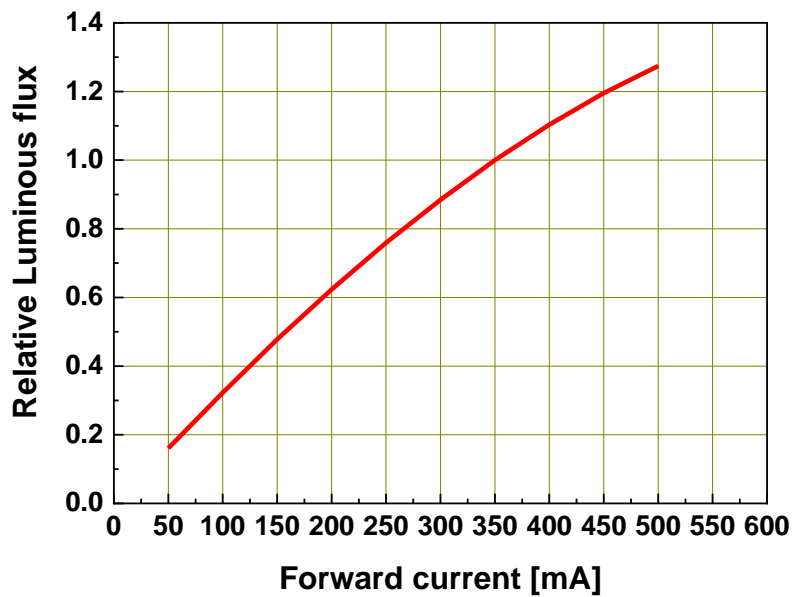

Dominant Wavelength vs. Forward Current @ Ts = 25°C

$$\Delta\lambda_d = \lambda_d - \lambda_d(350\text{mA}) = f(I_F)$$

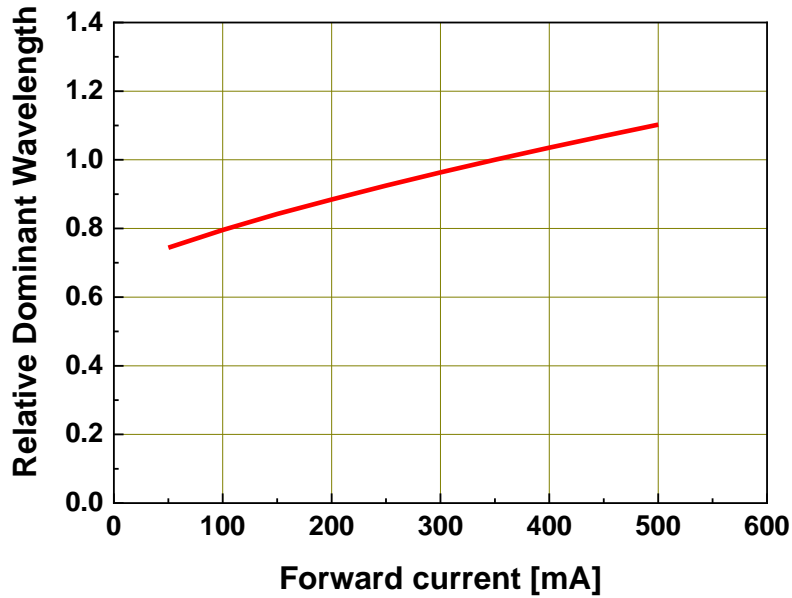

Relative Forward Voltage vs. Junction Temperature @ IF=350mA

$$\Delta V_F = V_F - V_F(25^\circ\text{C}) = f(T_j)$$

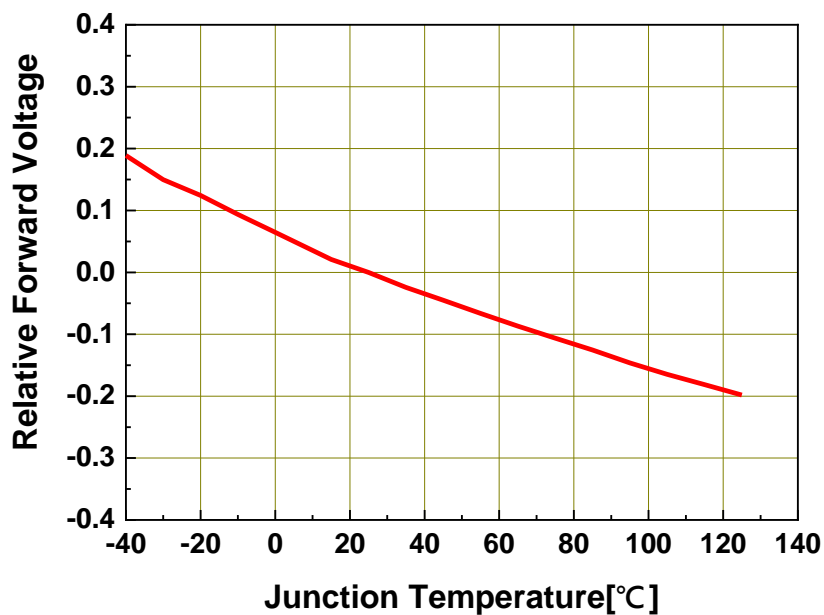

Relative Luminous flux vs. Junction Temperature

@ $I_F=350\text{mA}$

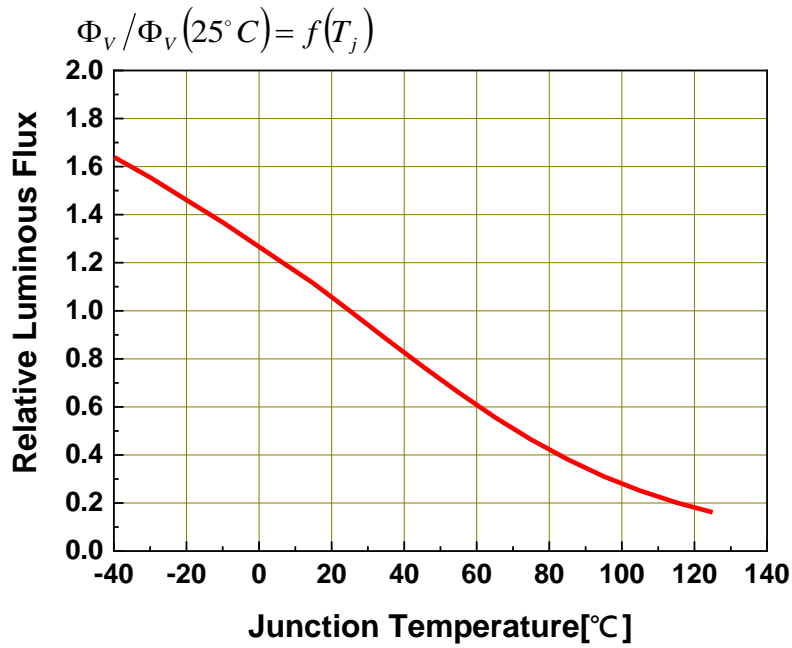

Relative Wavelength vs. Junction Temperature

@ $I_F=350\text{mA}$

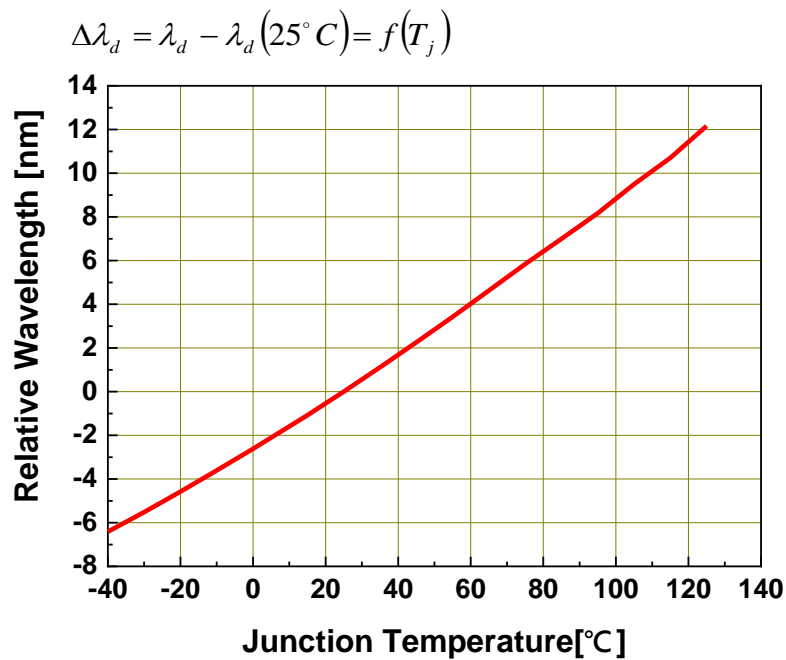

Forward Current Derating Curve

$$I_F = f(T_S)$$

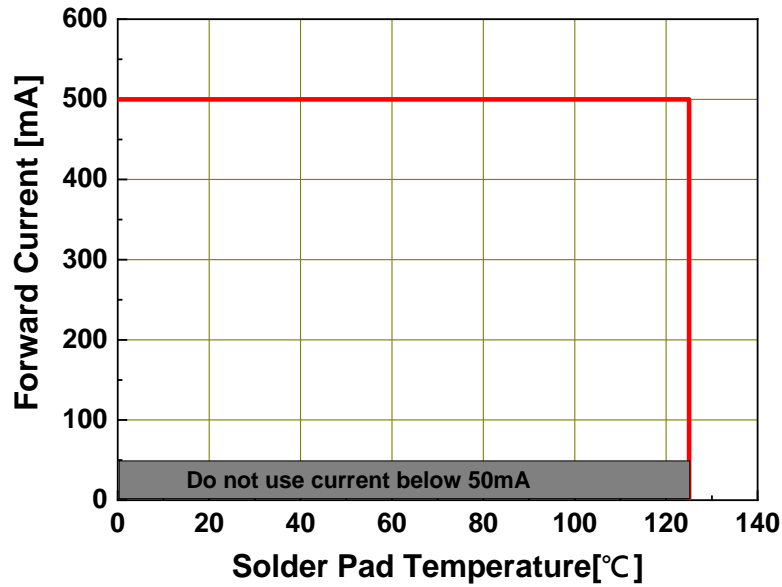

Permissible Pulse Handling Capability

D=Duty cycle , $T_s = 25^\circ\text{C}$

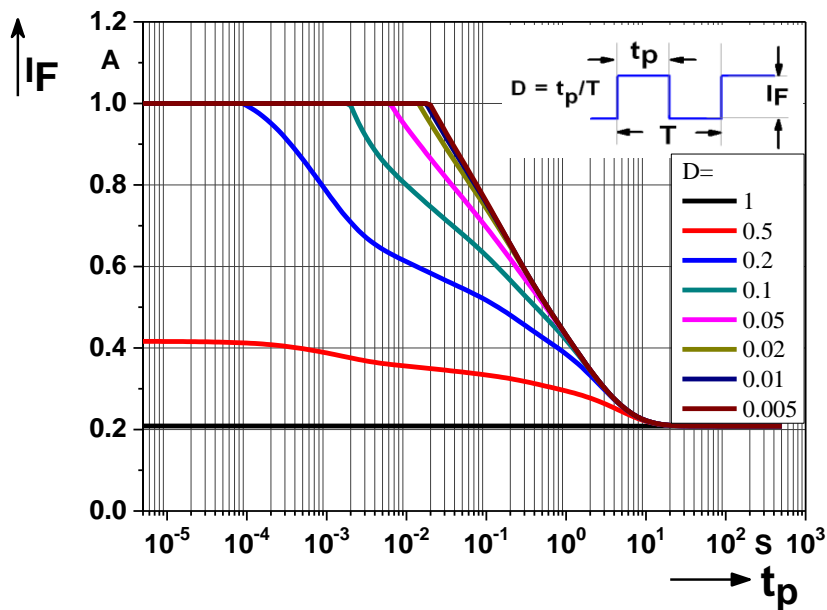

7. Part Number

2820-UR3501H-AM

Part number is designated with below details.

- 2820 = Product family name.
- UR= Color ^[1]
- 350 = Test current [mA]
- 1 = Lead Frame Type (0=Ag ; 1=Au)
- H = Brightness Level (H=High ; M=Medium ; L=Low)
- AM = Automotive application

- Note

^[1] Color :

Symbol	Description
C	Cool White
N	Neutral White
W	Warm White
PA	Phosphor Converted Amber
PR	Phosphor Converted Red
UB	Blue
IB	Ice Blue
SB	Sky Blue
UP	Purple
UG	Green
UY	Yellow
UYG	Brilliant Yellow Green
UPG	Pale Green
UA	Amber
UR	Red
SR	Super Red
RGB	RGB-Color
PYG	Phosphor Converted Yellow Green

8. Ordering Information

2820-UR3501H-**ABCDEFGHIJKLM**-NO-AM

Part Number	Order Code
2820-UR3501H-AM	2820-UR3501H-1227F5F81727-2T-AM

Order code contains information with below details :

1. ABCD = min/max wavelength or CCT
2. EFGH = min./max. luminous flux in [lm] or luminous intensity in [mcd]
3. JKLM = min./max. forward voltage
4. NO = Packing code
5. AM = Automotive Application

9. Reflow Soldering Profile

Soldering Condition (Reference: IPC/JEDEC J-STD-020D)

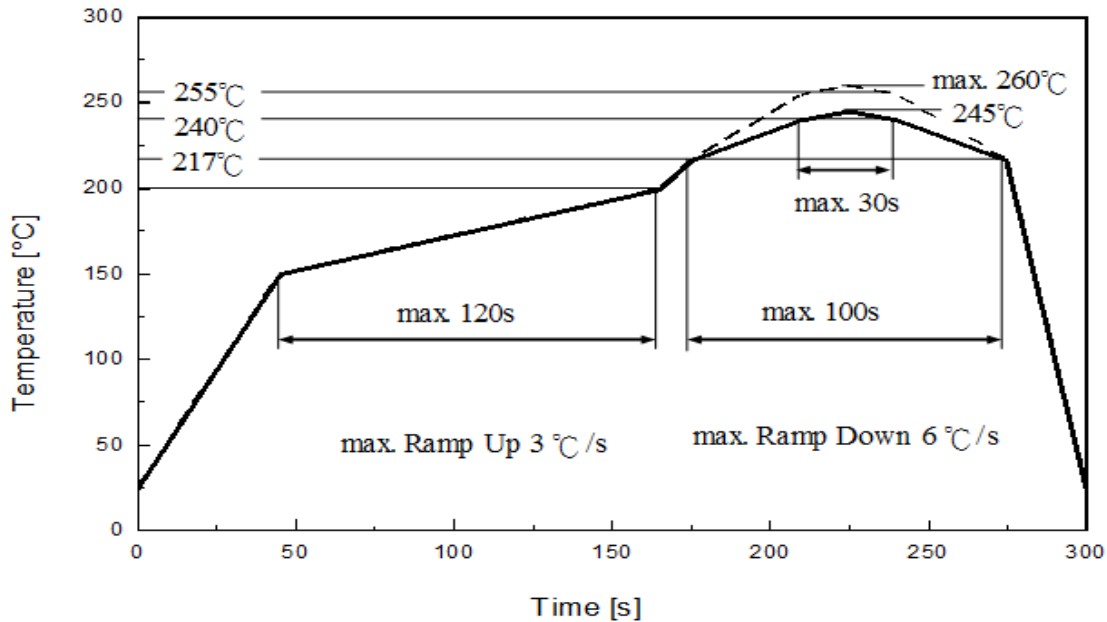

Profile Feature	Pb-Free Assembly	Unit
	Recommendation	
Ramp-up rate to preheat 25 °C to 150 °C	3	°C /sec
Time of soaking zone 150 °C to 200 °C	120	sec
Ramp-up rate to peak	3	°C /sec
Liquidus temperature	217	°C
Time above liquidus temperature	100	sec
Peak temperature (max.)	260	°C
Time within 5°C of the specified peak temperature	30	sec
Ramp-down Rate (max.)	6	°C /sec

10. Packaging Information

● Product Labeling



1. CPN : Customer's Product Number
2. P/N : Everlight Part Number
3. QTY : Packing Quantity
4. CAT : Luminous Flux (Brightness) Bin
5. HUE : Color Bin
6. REF : Forward Voltage Bin
7. LOT No : Lot Number

● Packing: Loaded Quantity 2000 pcs Per Reel

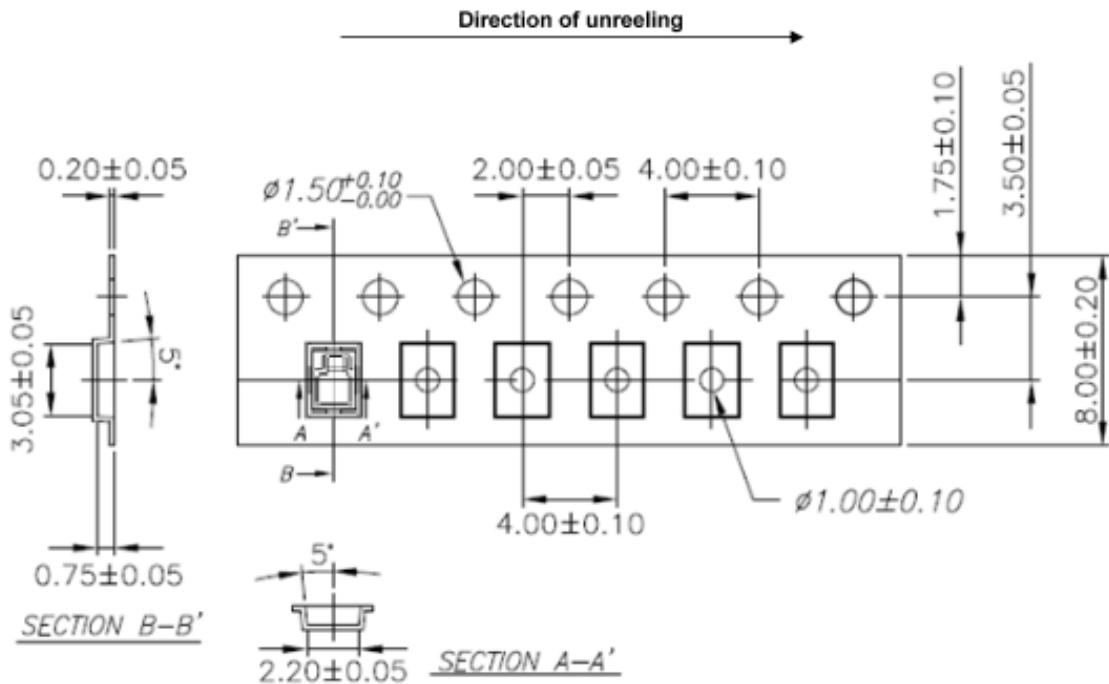

Notes:

Dimensions are in millimeters.

● **Reel Dimensions**

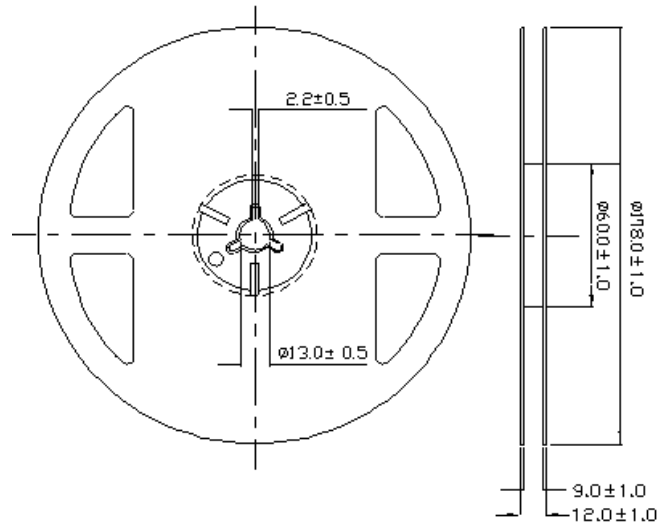

Notes:

1. Dimensions are in millimeters.

● **Moisture Resistant Packing Process**

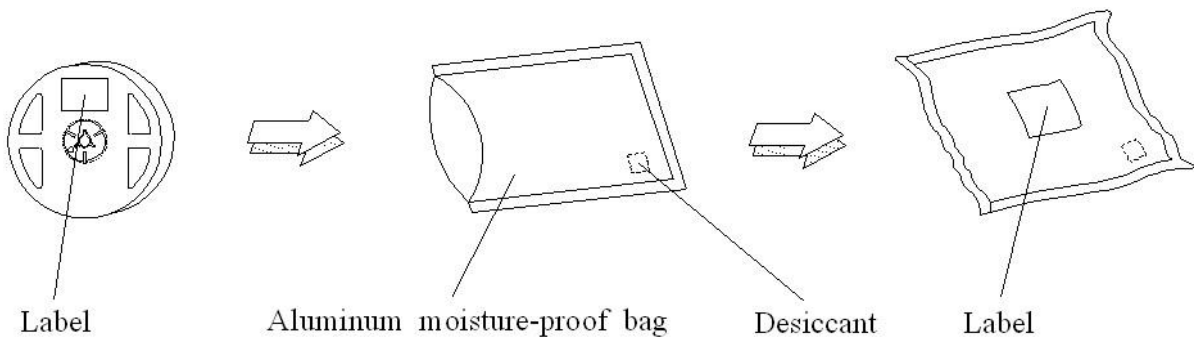

11. Precaution for Use

1. Over-current-proof

Customer must apply resistors for protection; otherwise slight voltage shift will cause big current change (burn out will happen).

2. Assemblies

Do not stack assemblies containing LEDs to prevent damage to the optical surface of LEDs. Forces applied to the optical surface may result in the surface being damaged.

3. Soldering Condition

3.1 When soldering, do not put stress on the LEDs during heating.

3.2 After soldering, do not warp the circuit board.

4. Soldering Iron

Each terminal is to go to the tip of soldering iron temperature less than 350°C for 3 seconds within once in less than the soldering iron capacity 25W. Leave two seconds and more intervals, and do soldering of each terminal. Be careful because the damage of the product is often started at the time of the hand solder.

5. Repairing

Repair should not be done after the LEDs have been soldered. When repairing is unavoidable, a double-head soldering iron should be used (as below figure). It should be confirmed beforehand whether the characteristics of the LEDs will or will not be damaged by repairing.

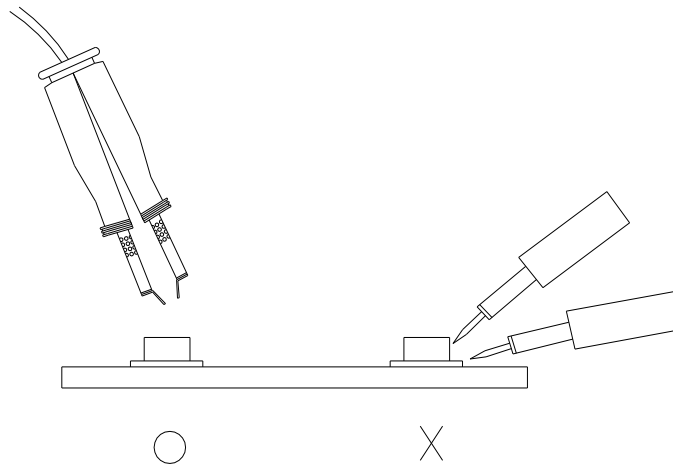

Revision History

Current version: 11.August.2021

Issue No:

Version: 1.0

Created by: Tom Xaio

Rev.	Subjects (major change in previous version)	Modified date
1	Standard data sheet	2021/08/11