

DATA SHEET

HIGH VOLTAGE AND ANTI-SULFURATED CHIP RESISTORS

AH series
0.5%, 1%, 5%
sizes 0603/0805/1206

RoHS compliant

IEC 62368-1 Safety Certificate issued by UL Demko:
sizes 0603/0805/1206



SCOPE

This specification describes AH0603/0805/1206 high voltage and anti-sulfurated chip resistors with lead-free terminations made by thick film process.

APPLICATIONS

- Converter
- Printer equipment
- Battery charger
- Computer
- Power supply
- Car electronics

FEATURES

- AEC-Q200 qualified
 - RoHS compliant
 - Reducing environmentally hazardous wastes
 - High component and equipment reliability
 - Non-forbidden materials used in products/production
 - Halogen Free Epoxy
 - Moisture sensitivity level: MSL 1
 - IEC 62368-1:2014 safety certificate (G.10.2) issued by UL Demko for the following sizes and resistance ranges:
 - 0603: 100KΩ to 10MΩ
 - 0805: 100KΩ to 22MΩ
 - 1206: 100KΩ to 27MΩ
- *Please refer to UL certification

ORDERING INFORMATION - GLOBAL PART NUMBER & I2NC

Both part numbers are identified by the series, size, tolerance, packing type, temperature coefficient, taping reel and resistance value.

YAGEO BRAND ordering code
GLOBAL PART NUMBER (PREFERRED)

AH XXXX X X X XX XXXX L
 (1) (2) (3) (4) (5) (6) (7)

(1) SIZE

0603/0805/1206

(2) TOLERANCE

D = ±0.5%
 F = ±1%
 J = ±5%

(3) PACKAGING TYPE

R = Paper/PE taping reel
 K = Embossed taping reel

(4) TEMPERATURE COEFFICIENT OF RESISTANCE

– = Base on spec

(5) TAPING REEL

07= 7 inch dia. Reel

(6) RESISTANCE VALUE

There are 2~4 digits indicated the resistor value. Letter R/K/M is decimal point, no need to mention the last zero after R/K/M, e.g.1K2, not 1K20.

Detailed resistance rules show in table of "Resistance rule of global part number".

(7) DEFAULT CODE

Letter L is system default code for ordering only ^(Note)

Resistance rule of global part number	
Resistance code rule	Example
XXKX (10 to 97.6 KΩ)	10K = 10,000 Ω 97K6 = 97,600 Ω
XXXX (100 to 976 KΩ)	100K = 100,000Ω 976K = 976,000Ω
XMXX (1 to 9.76 MΩ)	1M = 1,000,000 Ω 9M76 = 9,760,000 Ω
XXMX (10 to 16 MΩ)	10M = 10,000,000 Ω 27M = 27,000,000 Ω

ORDERING EXAMPLE

The ordering code of a AH1206 chip resistor, value 1 MΩ with ±5% tolerance, supplied in 7-inch tape reel is: AH1206JR-071ML.

NOTE

1. All our R-Chip products meet RoHS compliant. "LFP" of the internal 2D reel label mentions "Lead Free Process"
2. On customized label, "LFP" or specific symbol printed and the optional "L" at the end of GLOBAL PART NUMBER / I2NC can be added (both are on customer request)

MARKING

AH0603/0805/1206

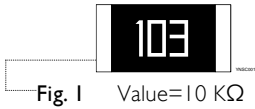

E-24 series: 3 digits, ±5%
First two digits for significant figure and 3rd digit for number of zeros

AH0603

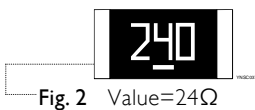

E-24 series: 3 digits, ±0.5% & ±1%
Exception values 10/11/13/15/20/75 of E24 series
One short bar under marking letter

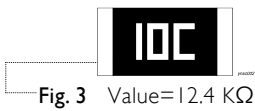

E-96 series: 3 digits, ±0.5% & ±1%
Including values 10/11/13/15/20/75 of E24 series
First two digits for E-96 marking rule and 3rd letter for number of zeros

AH0805/1206

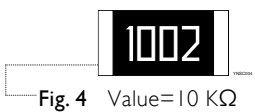

Both E-24 and E-96 series: 4 digits, ±0.5% & ±1%
First three digits for significant figure and 4th digit for number of zeros

For further marking information, please refer to data sheet “Chip resistors marking”.

CONSTRUCTION

The resistor is constructed on top of a high-grade ceramic body. Internal metal electrodes are added on each end to make the contacts to the thick film resistive element. The composition of the resistive element is a noble metal imbedded into a glass and covered by a second glass to prevent environment influences. The resistor is laser trimmed to the rated resistance value. The resistor is covered with a protective epoxy coat, finally the two external terminations (matte tin on Ni-barrier) are added. See fig.5

DIMENSIONS

Table I For outlines see fig. 5

TYPE	L (mm)	W (mm)	H (mm)	l ₁ (mm)	l ₂ (mm)
AH0603	1.60 ±0.10	0.80 ±0.10	0.45 ±0.10	0.25 ±0.15	0.25 ±0.15
AH0805	2.00 ±0.10	1.25 ±0.10	0.50 ±0.10	0.35 ±0.20	0.35 ±0.20
AH1206	3.10 ±0.10	1.60 ±0.10	0.55 ±0.10	0.45 ±0.20	0.45 ±0.20

OUTLINES

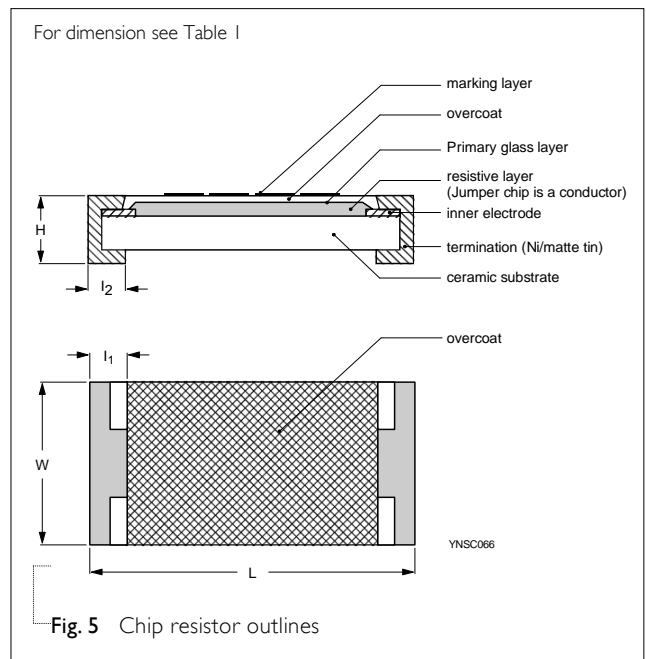

ELECTRICAL CHARACTERISTICS

Table 2

TYPE	RESISTANCE RANGE	CHARACTERISTICS					
		Rated Power	Operating Temperature Range	Max. Working Voltage	Max. Overload Voltage	Dielectric Withstanding Voltage	Temperature Coefficient of Resistance
AH0603	5% (E-24) 47Ω to 10MΩ	1/10W			350V	500V	500V
	1% (E-24/E-96) 47Ω to 10MΩ						
	0.5% (E-24/E-96) 47Ω to 10MΩ						
AH0805	5% (E-24) 47Ω to 22MΩ	1/8 W	-55 °C to +155 °C	400 V	800 V	800 V	±200 ppm/°C
	1% (E-24/E-96) 47Ω to 22MΩ						
	0.5% (E-24/E-96) 47Ω to 10MΩ						
AH1206	5% (E-24) 47Ω to 27MΩ	1/4 W		800 V	1,600 V	1,600 V	
	1% (E-24/E-96) 47Ω to 27MΩ						
	0.5% (E-24/E-96) 47Ω to 15MΩ						

FOOTPRINT AND SOLDERING PROFILES

For recommended footprint and soldering profiles, please refer to data sheet “Chip resistors mounting”.

PACKING STYLE AND PACKAGING QUANTITY

Table 3 Packing style and packaging quantity

PACKING STYLE	REEL DIMENSION	AH 0603	AH 0805	AH 1206
Paper/PE taping reel (R)	7" (178 mm)	5,000	5,000	5,000
Embossed taping reel (K)	7" (178 mm)	---	---	---

NOTE

1. For Paper/PE/Embossed tape and reel specification/dimensions, please refer to data sheet “Chip resistors packing”.

FUNCTIONAL DESCRIPTION

OPERATING TEMPERATURE RANGE

Range: -55 °C to +155 °C

POWER RATING

Each type rated power at 70 °C:

AH0603=1/10W; AH0805=1/8W; AH1206=1/4W

RATED VOLTAGE

The DC or AC (rms) continuous working voltage corresponding to the rated power is determined by the following formula:

$$V = \sqrt{(P \times R)}$$

or max. working voltage whichever is less

Where

V = Continuous rated DC or AC (rms) working voltage (V)

P = Rated power (W)

R = Resistance value (Ω)

Maximum working voltage can be applicable to resistors only if the resistance value is equal to or higher than the critical resistance value.

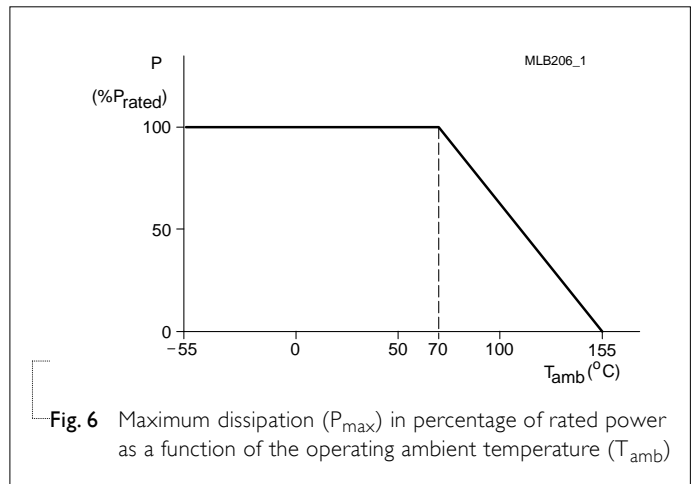

TESTS AND REQUIREMENTS**Table 4** Test condition, procedure and requirements

TEST	TEST METHOD	PROCEDURE	REQUIREMENTS
High Temperature Exposure	AEC-Q200 Test 3 MIL-STD-202 Method 108	1,000 hours at $T_A = 155\text{ °C}$, unpowered	$\pm(1.0\%+0.05\Omega)$
Moisture Resistance	AEC-Q200 Test 6 MIL-STD-202 Method 106	Each temperature / humidity cycle is defined at 8 hours (method 106F), 3 cycles / 24 hours for 10d. with $25\text{ °C} / 65\text{ °C}$ 95% R.H, without steps 7a & 7b, unpowered	$\pm(2.0\%+0.05\Omega)$
Biased Humidity	AEC-Q200 Test 7 MIL-STD-202 Method 103	1,000 hours; $85\text{ °C} / 85\%$ RH 10% of operating power Measurement at 24 ± 4 hours after test conclusion.	$\pm(5.0\%+0.05\Omega)$
Operational Life	AEC-Q200 Test 8 MIL-STD-202 Method 108	1,000 hours at 125 °C , derated voltage applied for 1.5 hours on, 0.5 hour off, still-air required	$\pm(3.0\%+0.05\Omega)$
Resistance to Soldering Heat	AEC-Q200 Test 15 MIL-STD-202 Method 210	Condition B, no pre-heat of samples Lead-free solder, $260\pm 5\text{ °C}$, 10 ± 1 seconds immersion time Procedure 2 for SMD: devices fluxed and cleaned with isopropanol	$\pm(1.0\%+0.05\Omega)$ No visible damage
Thermal Shock	AEC-Q200 Test 16 MIL-STD-202 Method 107	$-55/+125\text{ °C}$ Number of cycles is 300. Devices mounted Maximum transfer time is 20 seconds. Dwell time is 15 minutes. Air – Air	$\pm(1.0\%+0.05\Omega)$
ESD	AEC-Q200 Test 17 AEC-Q200-002	Human Body Model, $I_{pos.} + I_{neg.}$ discharges 0201: 500V 0402/0603: 1KV 0805 and above: 2KV	$\pm(4.0\%+0.05\Omega)$

TEST	TEST METHOD	PROCEDURE	REQUIREMENTS
Solderability - Wetting	AEC-Q200 Test I8 J-STD-002	Electrical Test not required Magnification 50X SMD conditions: (a) Method B, aging 4 hours at 155 °C dry heat, dipping at 235±3 °C for 5±0.5 seconds. (b) Method B, steam aging 8 hours, dipping at 215±3 °C for 5±0.5 seconds. (c) Method D, steam aging 8 hours, dipping at 260±3 °C for 30±0.5 seconds.	Well tinned (≥95% covered) No visible damage
Board Flex	AEC-Q200 Test 21 AEC-Q200-005	Chips mounted on a 90mm glass epoxy resin PCB (FR4) Bending for 0201/0402: 5 mm 0603/0805: 3 mm 1206 and above: 2 mm Holding time: minimum 60 seconds	±(1.0%+0.05Ω)
Temperature Coefficient of Resistance (T.C.R.)	MIL-STD-202 Method 304	At +25/-55 °C and +25/+125 °C Formula: $T.C.R = \frac{R_2 - R_1}{R_1(t_2 - t_1)} \times 10^6 \text{ (ppm/°C)}$ Where t ₁ =+25 °C or specified room temperature t ₂ =-55 °C or +125 °C test temperature R ₁ =resistance at reference temperature in ohms R ₂ =resistance at test temperature in ohms	Refer to table 2
Short Time Overload	IEC60115-1 4.13	2.5 times of rated voltage or maximum overload voltage whichever is less for 5 sec at room temperature	±(2.0%+0.05Ω)
FOS	ASTM-B-809-95* * Modified	Sulfur 750 hours, 105°C, unpowered	±(4.0%+0.05Ω)

REVISION HISTORY

REVISION	DATE	CHANGE NOTIFICATION	DESCRIPTION
Version 1	Aug. 03, 2022	-	- l2 dimension updated, for size l 206.
Version 0	Sep. 10, 2020	-	- First issue of this specification

“ YAGEO reserves all the rights for revising the content of this datasheet without further notification, as long as the products itself are unchanged. Any product change will be announced by PCN.”