

# DATA SHEET

**ELECTROSTATIC DISCHARGE  
PROTECTION DEVICES**

**INDUSTRIAL / CONSUMER**

UES08A05L05

RoHS compliant & Halogen free



Product specification— July 04, 2023 V.0



## Electrostatic Discharged Protection Devices (ESD) Data Sheet

### Description

Brightking's UES08A05L05 component is surge rated diode array designed to protect high speed data line interfaces. It has been specifically designed to protect sensitive components which are connected to data and transmission lines from overvoltage caused by electrostatic discharge (ESD), electrical fast transients (EFT), and lightning. The unique design of this device incorporates surge rated, low capacitance steering diodes and TVS diodes in a single package. During transient conditions, the steering diodes direct the transient either the position side of the power supply or to the ground.



Contact:  $\pm 8\text{kV}$   
Air:  $\pm 15\text{kV}$



### Features

- EC61000-4-2 ESD 15KV Air, 8KV contact compliance
- SOIC-08 surface mount package
- Protects four I/O lines and one power line
- Working voltage: 5V
- Low leakage current
- Low capacitance and clamping voltage
- Solid-state silicon avalanche technology
- Lead Free/RoHS compliant
- Solder reflow temperature: pure Tin-sn, 260-270°C
- Flammability rating UL 94V-0
- Meets MSL level 1, per J-STD-020
- Marking: B A055

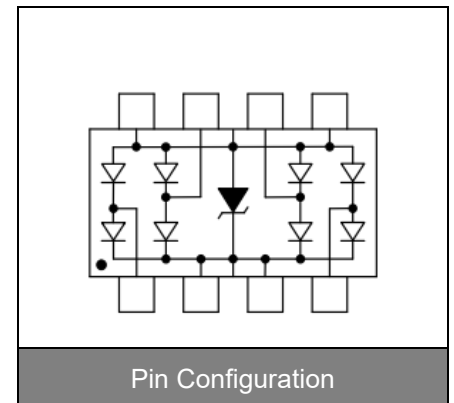

### Applications

- Ethernet 10/100/ base T
- Firewire & USB protection
- Set Top Box (STB) protection
- Video card (DVI) protection
- T1/E1 secondary IC side protection
- T3/E3 secondary IC side protection
- HDSL secondary IC side protection
- IC bus protection
- Micro-controller line protection

**Maximum Ratings**

Rating	Symbol	Value	Unit
Peak pulse current (tp=8/20us waveform)	I <sub>PP</sub>	25	A
ESD voltage (Contact discharge)	V <sub>ESD</sub>	±8	KV
ESD voltage (Air discharge)		±15	
Storage & operating temperature range	T <sub>STG</sub> , T <sub>J</sub>	-55~+150	°C

**Electrical Characteristics (T<sub>J</sub>=25°C)**

Parameter	Symbol	Condition	Min.	Max.	Unit
Reverse stand-off voltage	V <sub>RWM</sub>			5	V
Reverse breakdown voltage	V <sub>BR</sub>	I <sub>BR</sub> =1mA	6		V
Reverse leakage current	I <sub>R</sub>	V <sub>R</sub> =5V Each I/O pin		1	uA
Clamping voltage (tp=8/20us)	V <sub>C</sub>	I <sub>PP</sub> =1A		9.8	V
Clamping voltage (tp=8/20us)	V <sub>C</sub>	I <sub>PP</sub> =10A		13.5	V
Off state junction capacitance	C <sub>J</sub>	0Vdc, f=1MHz Between I/O pins and GND		5	pF

**Applications Information**

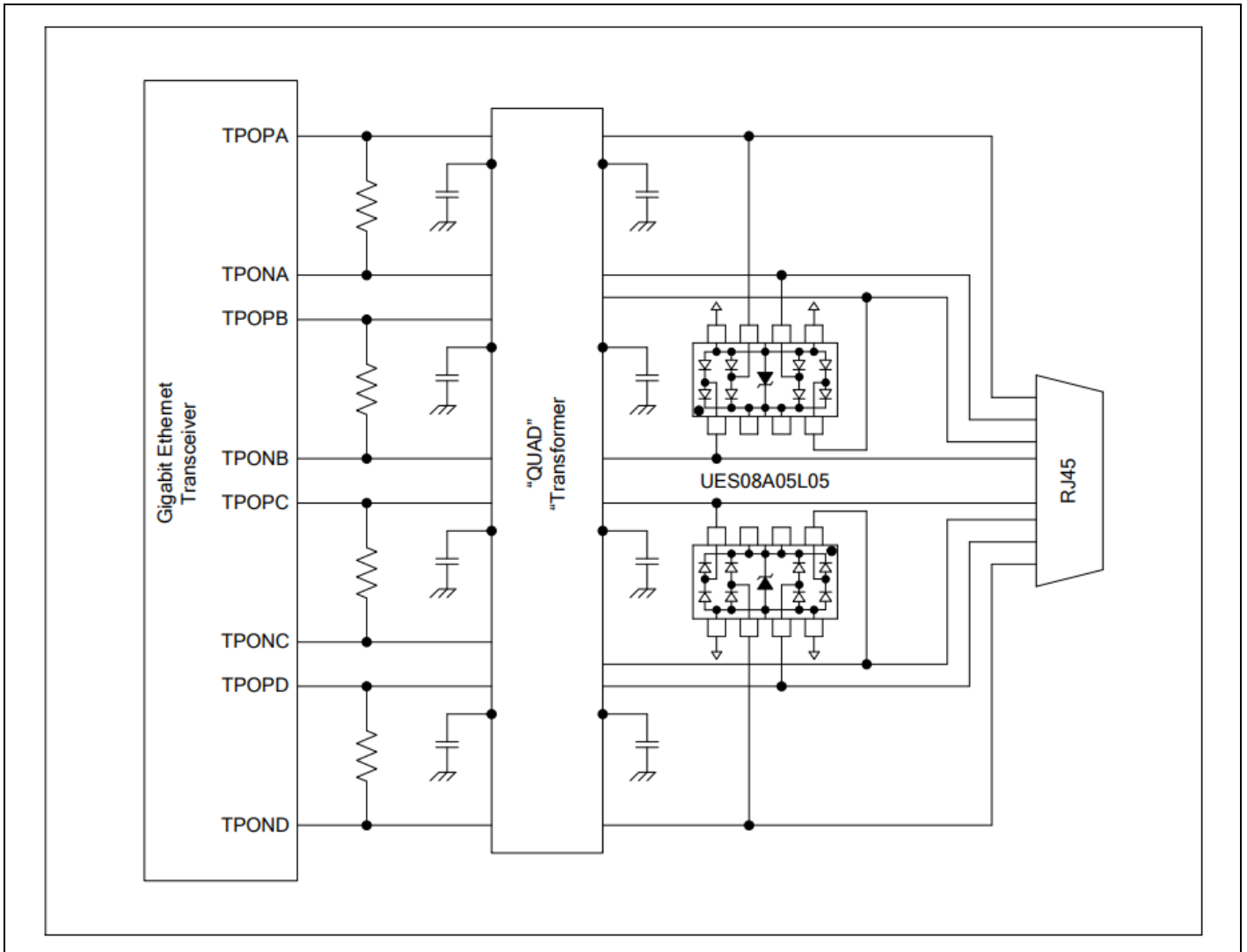

**Typical Characteristics Curves**

Figure 1. Figure 1. Pulse Waveforms

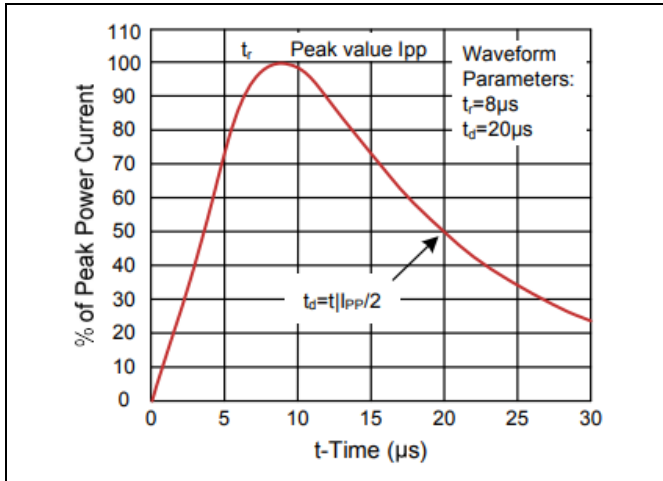

Figure 2. Clamping Voltage vs. Peak Pulse Current

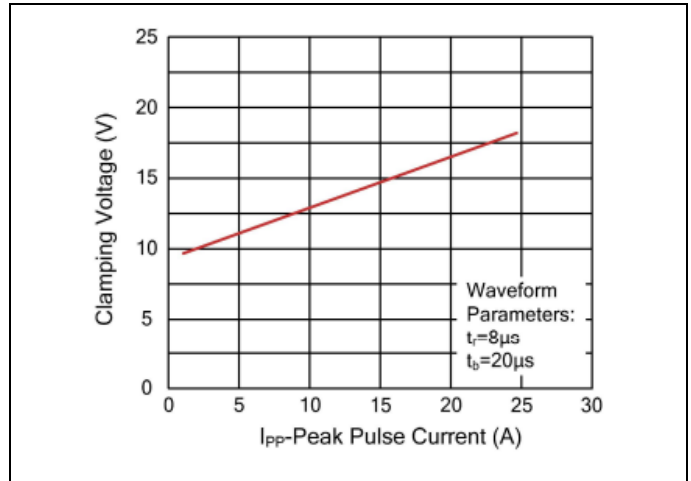
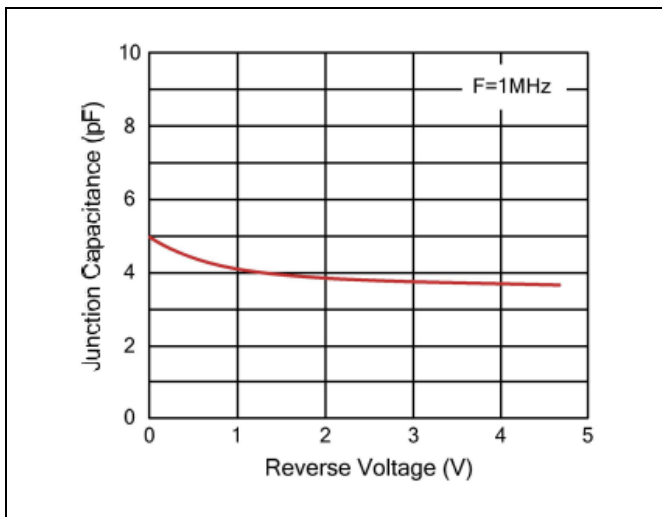
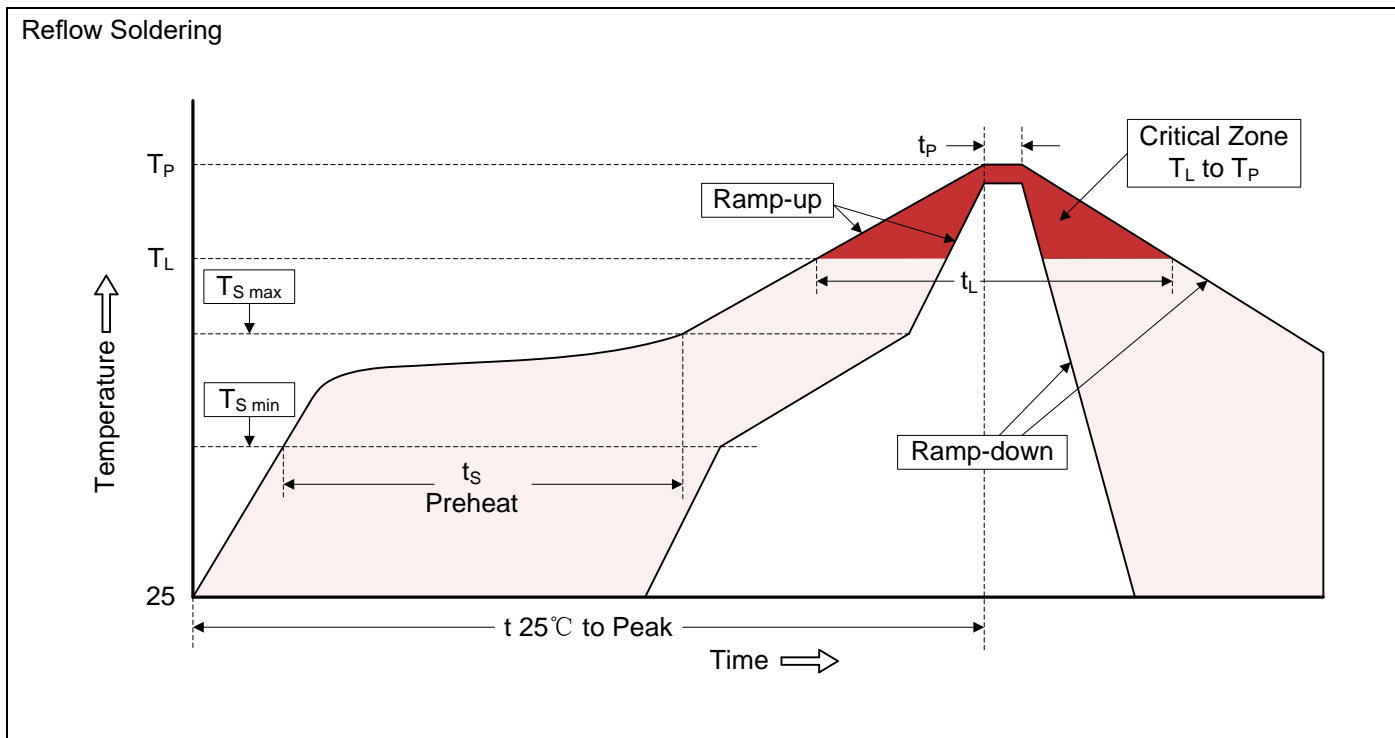

Figure 3. Capacitance vs. Reverse Voltage



**Recommended Soldering Conditions**



**Recommended Conditions**

Profile Feature	Pb-Free Assembly
Average ramp-up rate ( $T_L$ to $T_P$ )	3°C/second max.
Preheat -Temperature Min ( $T_{S\ min}$ ) -Temperature Max ( $T_{S\ max}$ ) -Time (min to max) ( $t_s$ )	150°C 200°C 60-180 seconds
$T_{S\ max}$ to $T_L$ -Ramp-up Rate	3°C/second max.
Time maintained above: -Temperature ( $T_L$ ) -Time ( $t_L$ )	217°C 60-150 seconds
Peak Temperature ( $T_P$ )	260°C
Time within 5°C of actual Peak Temperature ( $t_p$ )	20-40 seconds
Ramp-down Rate	6°C/second max.
Time 25°C to Peak Temperature	8 minutes max.

**Dimensions (SOIC-08)**

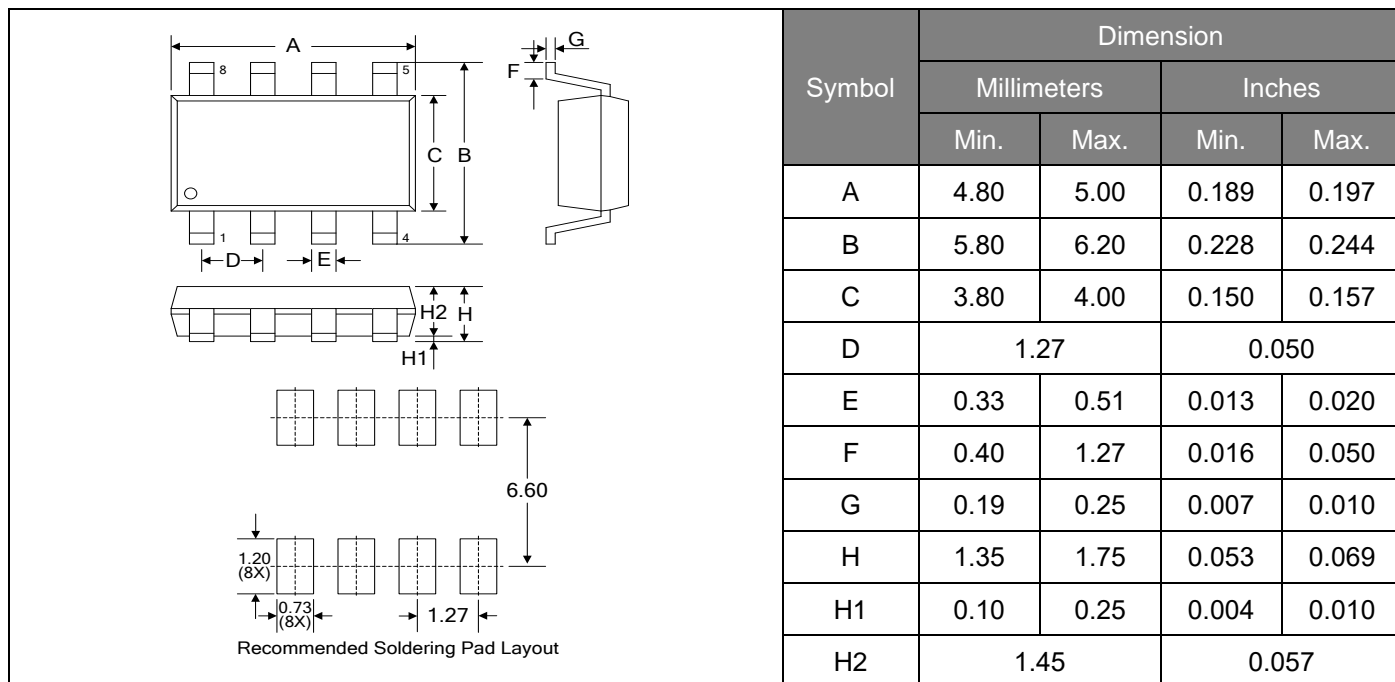

**Packaging**

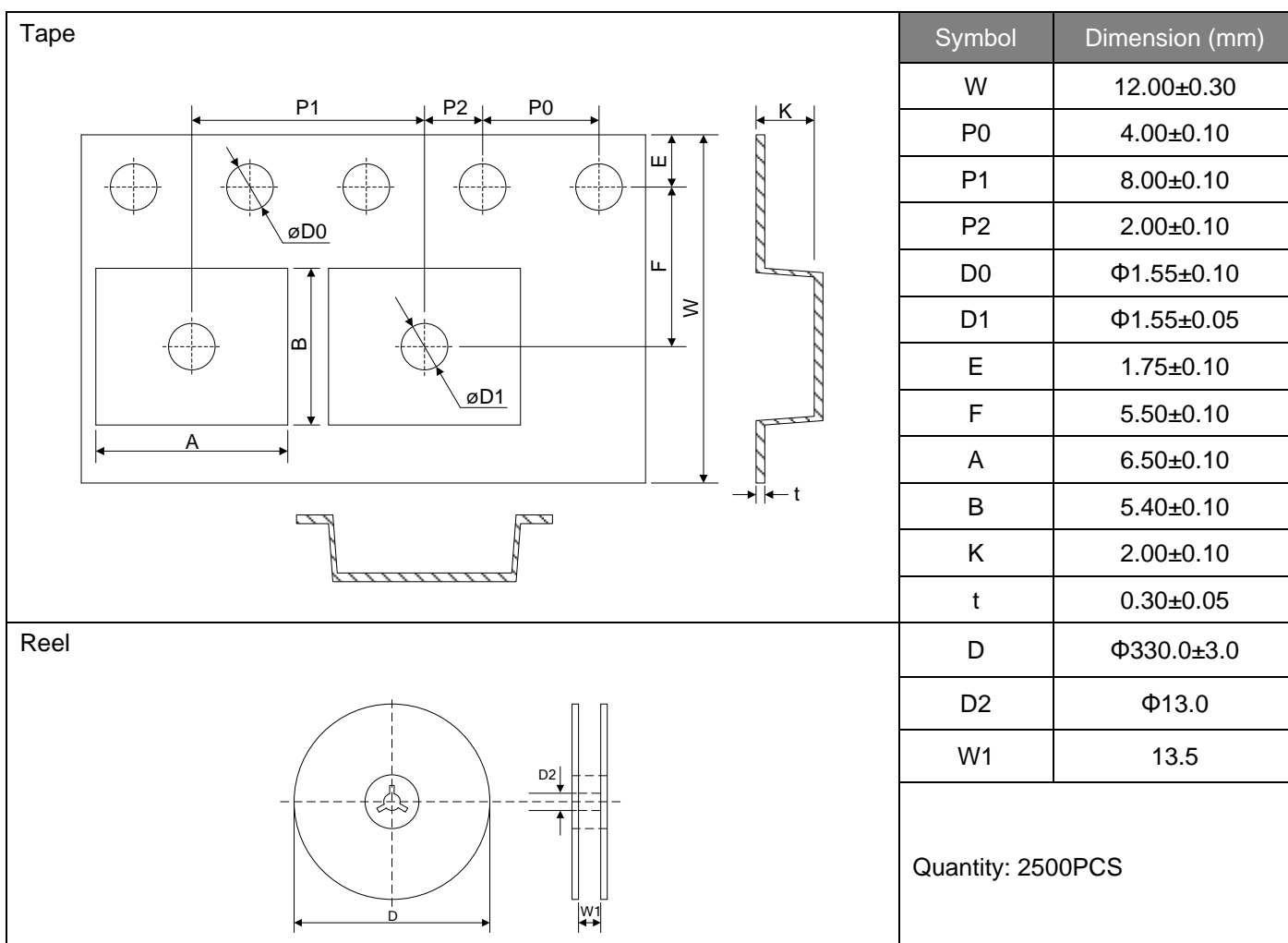

## LEGAL DISCLAIMER

YAGEO, its distributors and agents (collectively, "YAGEO"), hereby disclaims any and all liabilities for any errors, inaccuracies or incompleteness contained in any product related information, including but not limited to product specifications, datasheets, pictures and/or graphics. YAGEO may make changes, modifications and/or improvements to product related information at any time and without notice.

YAGEO makes no representation, warranty, and/or guarantee about the fitness of its products for any particular purpose or the continuing production of any of its products. To the maximum extent permitted by law, YAGEO disclaims (i) any and all liability arising out of the application or use of any YAGEO product, (ii) any and all liability, including without limitation special, consequential or incidental damages, and (iii) any and all implied warranties, including warranties of fitness for a particular purpose, non-infringement and merchantability.

YAGEO products are designed for general purpose applications under normal operation and usage conditions. Please contact YAGEO for the applications listed below which require especially high reliability for the prevention of defects which might directly cause damage to the third party's life, body or property: Aerospace equipment (artificial satellite, rocket, etc.), Atomic energy-related equipment, Aviation equipment, Disaster prevention equipment, crime prevention equipment, Electric heating apparatus, burning equipment, Highly public information network equipment, data-processing equipment, Medical devices, Military equipment, Power generation control equipment, Safety equipment, Traffic signal equipment, Transportation equipment and Undersea equipment, or for any other application or use in which the failure of YAGEO products could result in personal injury or death, or serious property damage. Particularly **YAGEO Corporation and its affiliates do not recommend the use of commercial or automotive grade products for high reliability applications or manned space flight.**

Information provided here is intended to indicate product specifications only. YAGEO reserves all the rights for revising this content without further notification, as long as products are unchanged. Any product change will be announced by PCN.