

Programmable VCXO/VCSO VG7050ECN

SEIKO EPSON CORPORATION

Product name VG7050ECN SM20T003 CJGLPZ
 Product code / Ordering code X1G0045611003xx

Please refer to the 8.Packing information about xx (last 2 digits)

Output waveform LV-PECL
 Pb free / Complies with EU RoHS directive
 Reference weight Typ.168mg

1.Absolute maximum ratings						
Parameter	Symbol	Min.	Typ.	Max.	Unit	Conditions / Remarks
Maximum supply voltage	Vcc-GND	-0.3	-	+4	V	-
Storage temperature	T_stg	-55	-	+125	°C	-
Input voltage	Vin	GND-0.3	-	Vcc+0.3	V	Except SDA and SCL pin

2.Specifications(characteristics)						
Parameter	Symbol	Min.	Typ.	Max.	Unit	Conditions / Remarks
Output frequency	f0		622.080000		MHz	Start-up frequency-1
			644.531250		MHz	Start-up frequency-2
			669.326582		MHz	Start-up frequency-3
			693.482991		MHz	Start-up frequency-4
Supply voltage	Vcc	2.97	3.3	3.63	V	-
Control voltage	Vc	0.3	1.65	3	V	Vc=1.65V+/-1.35V
Operating temperature	T_use	-40	-	+85	°C	-
Frequency tolerance	f_tol	-50	-	+50	x10 ⁻⁶	includes 10 years aging
Current consumption	Icc	-	-	90	mA	OE = Active L_ECL =50Ω
Disable current	I_dis	-	-	40	mA	OE inactive ,output standby:Hi-Z mode
Frequency control range	f_cont	-50 to +/-23	-	-	x10 ⁻⁶	-
Absolute pull range	APR	+/-0 to +/-180			x10 ⁻⁶	Programmable
Modulation characteristics	BW	10	-	-	kHz	+/-3 dB
Input resistance	Rin	5000	-	-	kΩ	DC Level
Frequency change polarity	-					Positive polarity
Symmetry	SYM	45	-	55	%	at outputs crossing point
Output voltage	V _{OH}	Vcc-1.025	-	-	V	-
	V _{OL}	-	-	Vcc-1.62	V	-
Output load condition	L_ECL	-	50	-	Ω	Outputs terminated to Vcc-2.0V
Input voltage	V _{IH}	70%Vcc	-	-	V	OE,FSEL0,FSEL1,SDA,SCL
	V _{IL}	-	-	30%Vcc	V	OE,FSEL0,FSEL1,SDA,SCL
Rise time	tr	-	-	0.4	ns	20 % to 80 % of amplitude
Fall time	tf	-	-	0.4	ns	20 % to 80 % of amplitude
Start-up time	t_str	-	-	10	ms	-
Phase noise	F _{CN}	-	-75.7	-	dBc/Hz	Offset 100Hz
		-	-101.6	-	dBc/Hz	Offset 1kHz
		-	-118.8	-	dBc/Hz	Offset 10kHz
		-	-121.3	-	dBc/Hz	Offset 100kHz
		-	-129.3	-	dBc/Hz	Offset 1MHz
Phase jitter	t _{PJ}	-	0.3	-	ps	Offset Frequency: 12kHz to 20MHz
Frequency aging	f_aging	-	-	-	x10 ⁻⁶	Included in frequency tolerance

3. Block diagram

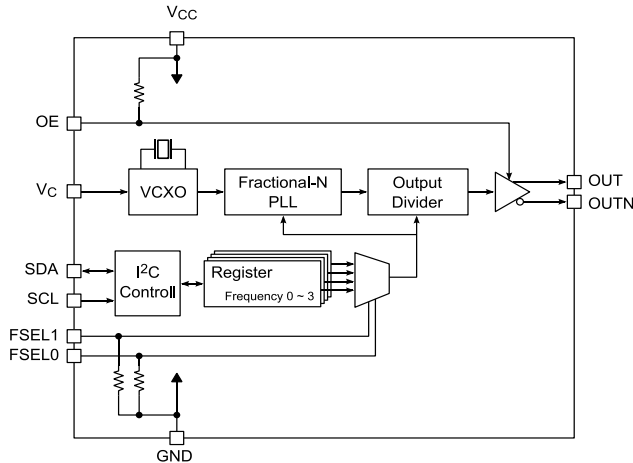

4. OE Function / OE Standby typ

OE Function	OE Standby Type	Frequency output OE pin	Oscillator Stop	
			OE pin	OUT,OUTN state
H: High Active	Z: High-Z	"H" or "OPEN"	"L"	High Impedance
L: Low Active		"L" or "OPEN"	"H"	
H: High Active	F: Fix	"H" or "OPEN"	"L"	OUT="L", OUTN="H"
L: Low Active		"L" or "OPEN"	"H"	

3. Timing chart

Output wave form

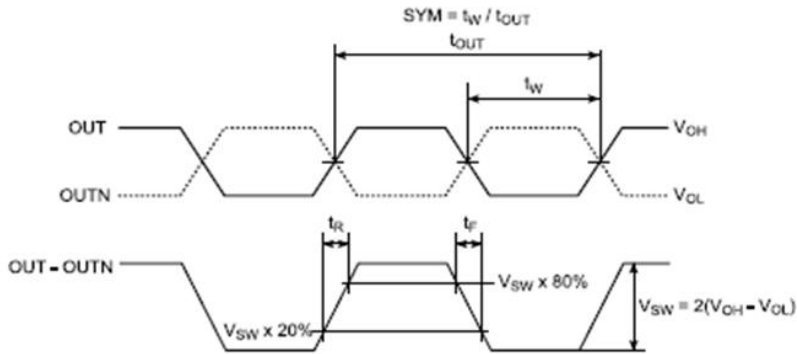

Output Rise/Fall Time, Symmetry (duty cycle)

4. Test circuit

1) Condition

This figure shows an example of this product's application schematic.

As with any high speed analog circuitry, the power supply pins for VG7050EAN are vulnerable to noise. In order to achieve optimum jitter performance, power isolation with filter device is required for power supply pins.

In order to achieve best performance of the power isolation filter, it is recommended that the filter composing devices is placed on the device side of the PCB as close to the power pins as possible. The component value of this filter is just an example, it may have to be adjusted.

2) $V_{CC} = 3.3V$

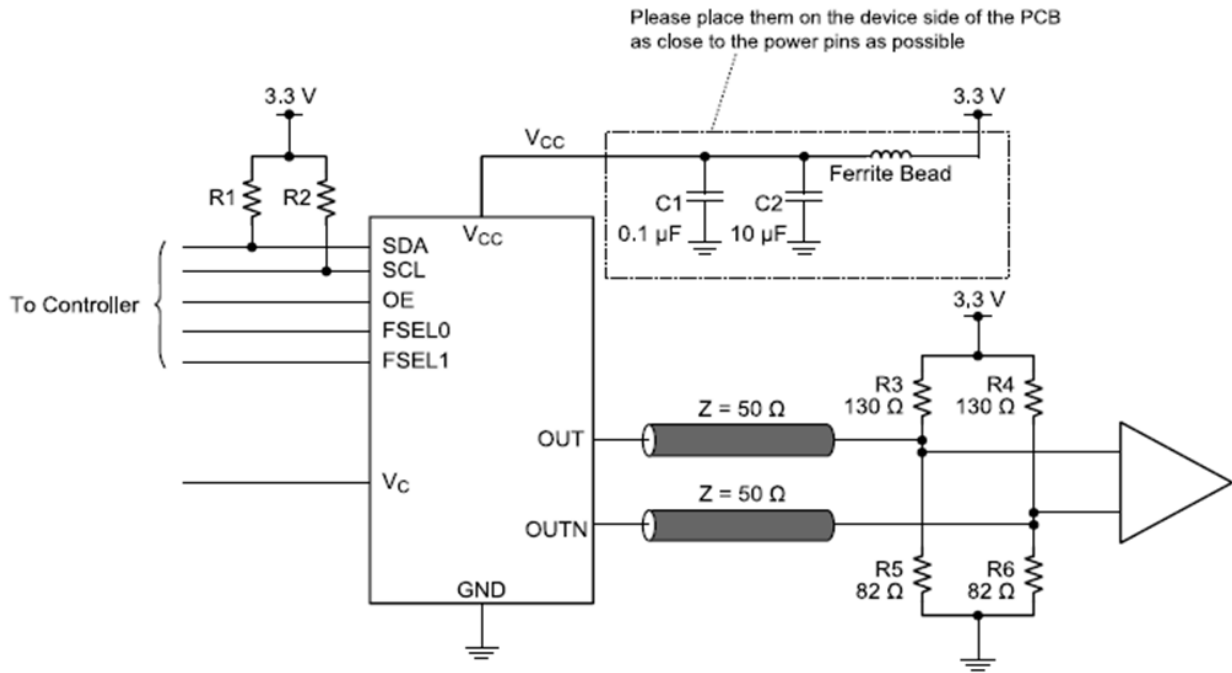

3) $V_{CC} = 2.5V$

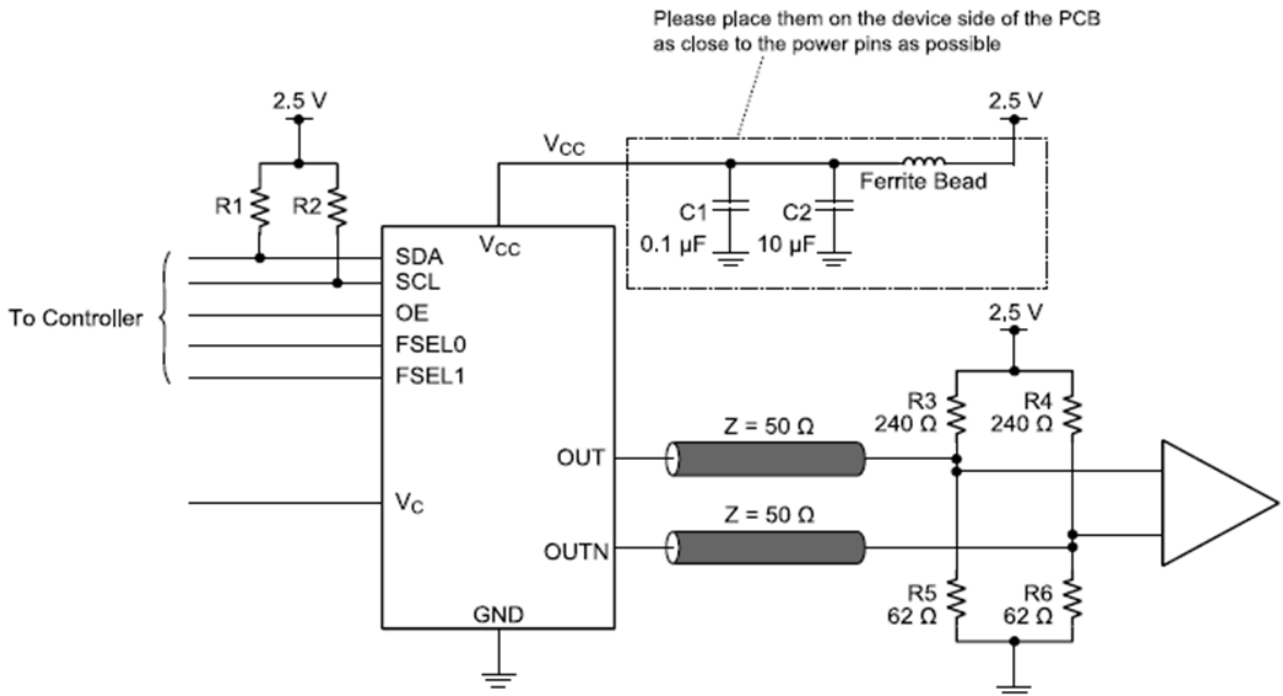

5.External dimensions (Unit: mm)

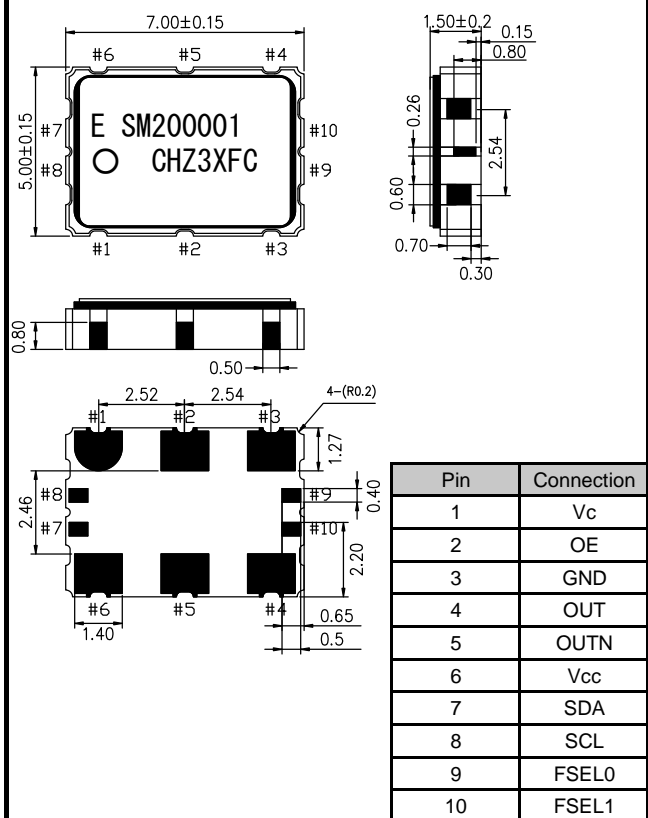

6.Footprint(Recommended) (Unit: mm)

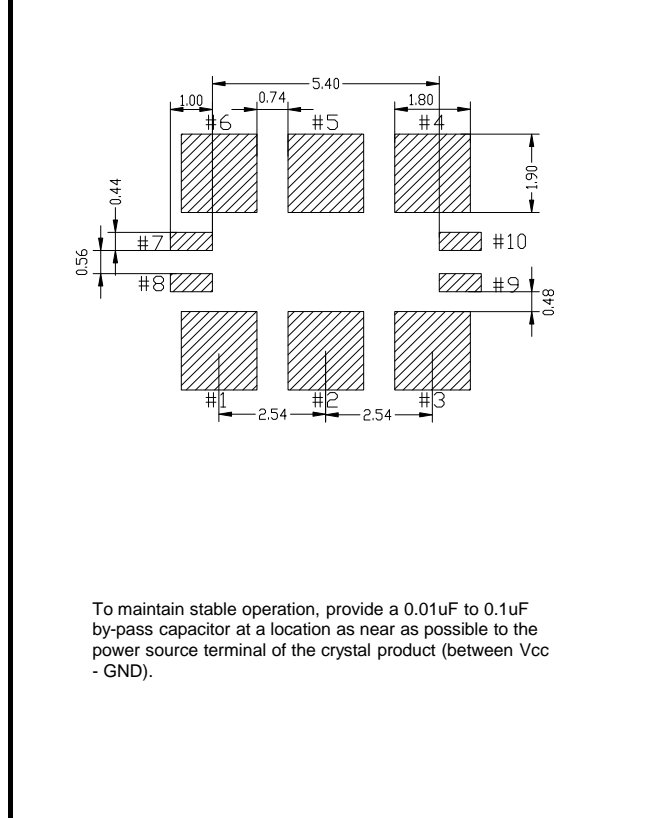

7.Reflow profile

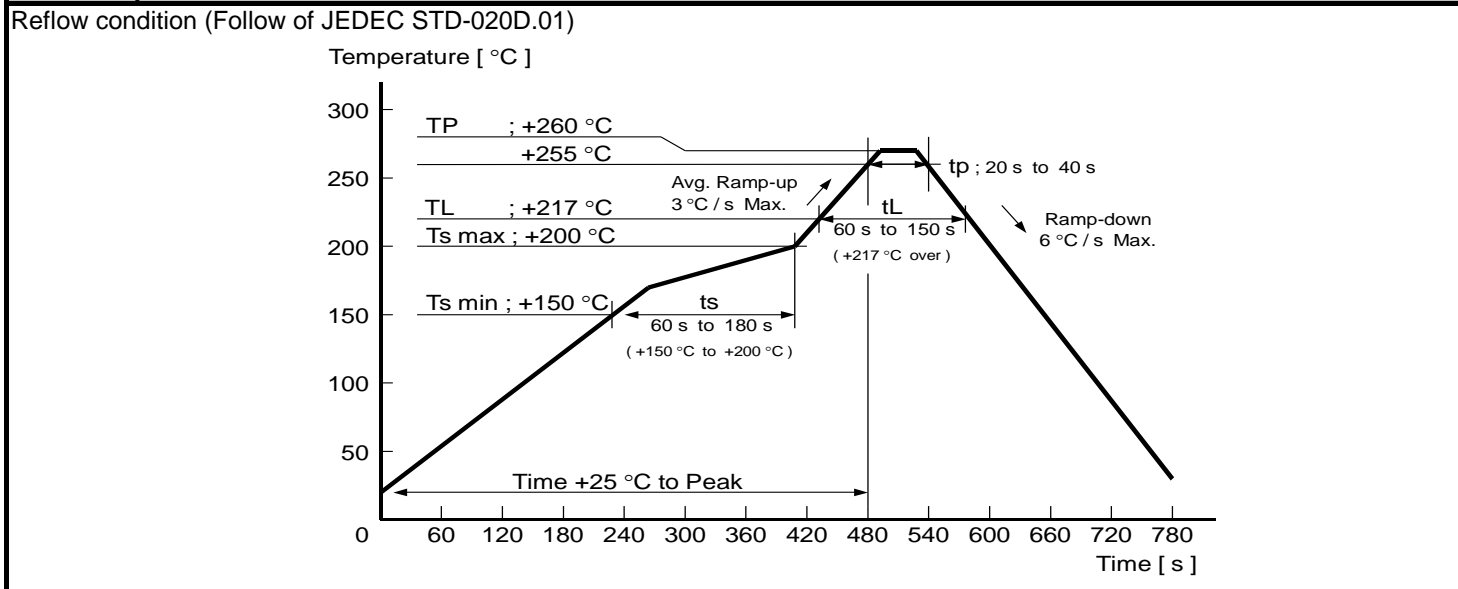

8.Packing information

[1] Product number last 2 digits code(xx) description The recommended code is "00"

X1G0045611003xx

Code	Condition	Code	Condition
00	1000pcs / Reel	12	250pcs / Reel
01	Any Q'ty vinyl bag(Tape cut)	13	500pcs / Reel
11	Any Q'ty / Reel		

[2] Taping specification

Subject to EIA-481 & IEC-60286

(1) Tape dimensions

Material of the Carrier Tape : PS

Material of the Top Tape : PET+PE

Unit: mm

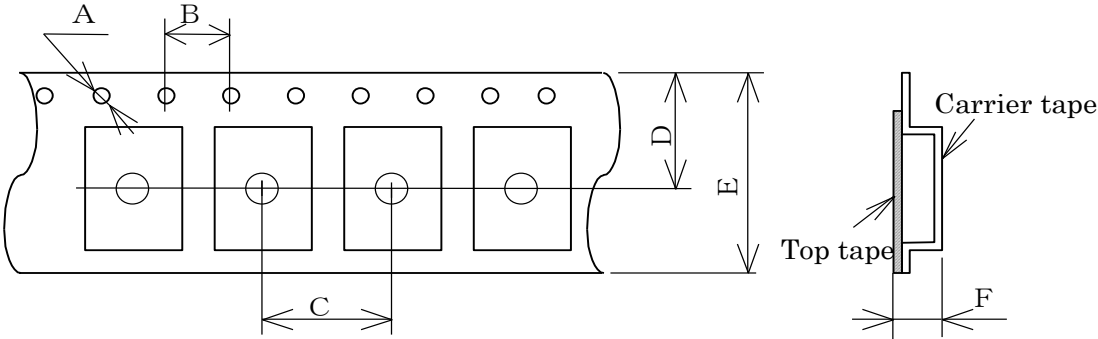

Symbol	A	B	C	D	E	F
Value	Φ1.5	4	8	9.25	16	2.3

(2) Reel dimensions

Center material : PS

Material of the Reel : PS

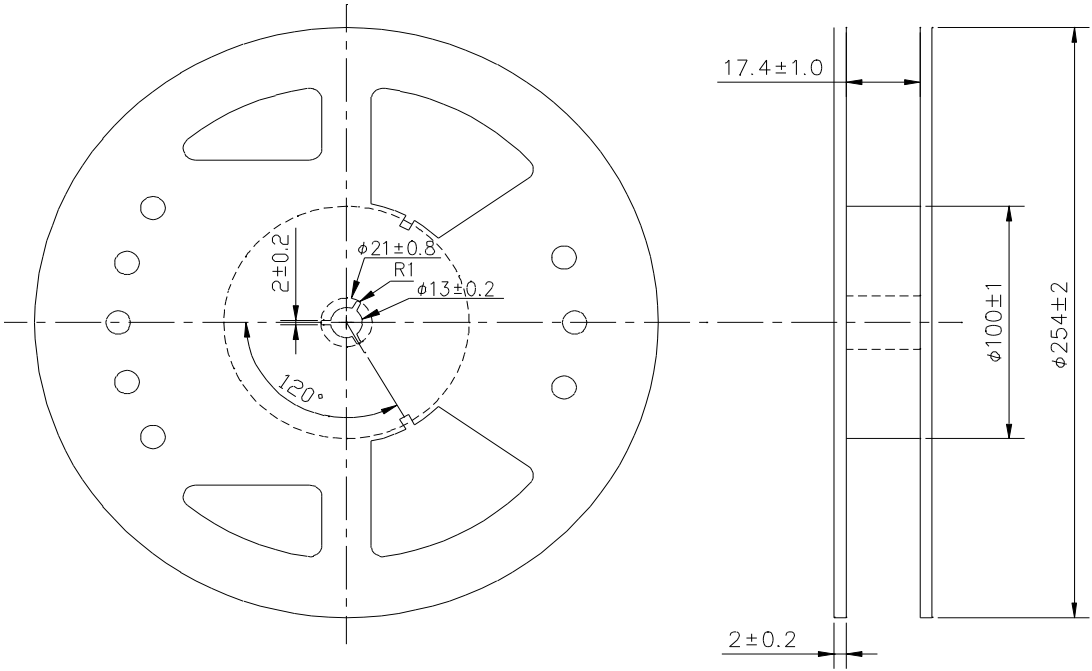

9. Notice

- This material is subject to change without notice.
- Any part of this material may not be reproduced or duplicated in any form or any means without the written permission of Seiko Epson.
- The information about applied circuitry, software, usage, etc. written in this material is intended for reference only. Seiko Epson does not assume any liability for the occurrence of infringing on any patent or copyright of a third party. This material does not authorize the licensing for any patent or intellectual copyrights.
- When exporting the products or technology described in this material, you should comply with the applicable export control laws and regulations and follow the procedures required by such laws and regulations.
- You are requested not to use the products (and any technical information furnished, if any) for the development and/or manufacture of weapon of mass destruction or for other military purposes. You are also requested that you would not make the products available to any third party who may use the products for such prohibited purposes.
- These products are intended for general use in electronic equipment. When using them in specific applications that require extremely high reliability, such as the applications stated below, you must obtain permission from Seiko Epson in advance.
 - / Space equipment (artificial satellites, rockets, etc.)
 - / Transportation vehicles and related (automobiles, aircraft, trains, vessels, etc.)
 - / Medical instruments to sustain life
 - / Submarine transmitters
 - / Power stations and related
 - / Fire work equipment and security equipment
 - / Traffic control equipment
 - / And others requiring equivalent reliability.
- All brands or product names mentioned herein are trademarks and/or registered trademarks of their respective.

10. Contact us

<http://www5.epsondevice.com/en/contact/>