

SMBG Plastic-Encapsulate Diodes

CJSMBJ SERIES Transient Voltage Suppressor Diodes

Features

- P_{PP} 600W
- V_{RWM} 5V- 100V
- Glass passivated chip

Applications

- Clamping Voltage

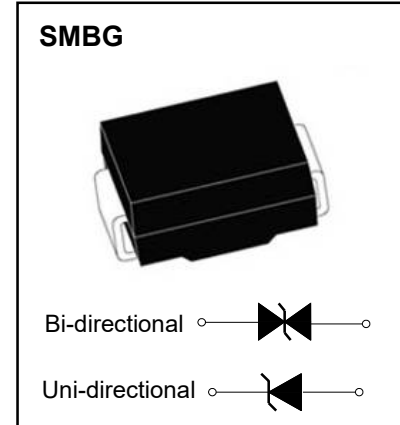

Limiting Values (Absolute Maximum Rating)

Item	Symbol	Unit	Conditions	Max
Peak pulse power dissipation	P_{PPM}	W	with a 10/1000us waveform	600
Peak pulse current(note 1)	I_{PPM}	A	with a 10/1000us waveform	See Next Table
Power dissipation	P_D	W	On infinite heat sink at $T_L=50^\circ\text{C}$	5.0
Peak forward surge current	I_{FSM}	A	8.3 ms single half sine-wave uni-directional only (note 2)	100
Operating junction and storage temperature range	T_J, T_{STG}	$^\circ\text{C}$		-55 to +150

Electrical Characteristics ($T_a=25^\circ\text{C}$ Unless otherwise specified)

Item	Symbol	Unit	Conditions	Max
Maximum instantaneous forward Voltage	V_F	V	at 50A for uni-directional only	3.5
Thermal resistance	$R_{\theta JL}$	$^\circ\text{C}/\text{W}$	junction to lead $T_L=50^\circ\text{C}$	20
	$R_{\theta JA}$	$^\circ\text{C}/\text{W}$	junction to ambient $T_A=25^\circ\text{C}$	100

Notes:

- (1) Non-repetitive current pulse, per Fig. 3 and derated above $T_A=25^\circ\text{C}$ per Fig.2
- (2) 8.3ms single half sine-wave or equivalent square wave, duty cycle=4 pulses per minutes maximum

Electrical Characteristics (T_A=25°C unless otherwise noted)

Part Number		Device Marking Code		Breakdown Voltage VBR@IT		Test Current	Max Reverse Leakage @VRWM	Reverse Standoff Voltage	Max Peak Pulse Current ⁽¹⁾	Max Clamping Voltage @Ipp
UNI	BI	UNI	BI	Min.(V)	Max.(V)	IT(mA)	IR (uA)	V _{RWM} (V)	IPP(A)	V _c (V)
CJSMBJ5.0A	CJSMBJ5.0CA	B5.0A XX ⁽²⁾	B5.0CA XX	6.40	7.00	10	800	5	65.3	9.2
CJSMBJ6.0A	CJSMBJ6.0CA	B6.0A XX	B6.0CA XX	6.67	7.37	10	800	6	58.3	10.3
CJSMBJ6.5A	CJSMBJ6.5CA	B6.5A XX	B6.5CA XX	7.22	7.98	10	500	6.5	53.6	11.2
CJSMBJ7.0A	CJSMBJ7.0CA	B7.0A XX	B7.0CA XX	7.78	8.60	10	200	7	50.0	12.0
CJSMBJ7.5A	CJSMBJ7.5CA	B7.5A XX	B7.5CA XX	8.33	9.21	1	100	7.5	46.6	12.9
CJSMBJ8.0A	CJSMBJ8.0CA	B8.0A XX	B8.0CA XX	8.89	9.83	1	50	8	44.2	13.6
CJSMBJ8.5A	CJSMBJ8.5CA	B8.5A XX	B8.5CA XX	9.44	10.40	1	20	8.5	41.7	14.4
CJSMBJ9.0A	CJSMBJ9.0CA	B9.0A XX	B9.0CA XX	10.00	11.10	1	10	9	39.0	15.4
CJSMBJ10A	CJSMBJ10CA	B10A XX	B10CA XX	11.10	12.30	1	5	10	35.3	17.0
CJSMBJ11A	CJSMBJ11CA	B11A XX	B11CA XX	12.20	13.50	1	5	11	33.0	18.2
CJSMBJ12A	CJSMBJ12CA	B12A XX	B12CA XX	13.30	14.70	1	5	12	30.2	19.9
CJSMBJ13A	CJSMBJ13CA	B13A XX	B13CA XX	14.40	15.90	1	5	13	28.0	21.5
CJSMBJ14A	CJSMBJ14CA	B14A XX	B14CA XX	15.60	17.20	1	5	14	25.9	23.2
CJSMBJ15A	CJSMBJ15CA	B15A XX	B15CA XX	16.70	18.50	1	5	15	24.6	24.4
CJSMBJ16A	CJSMBJ16CA	B16A XX	B16CA XX	17.80	19.70	1	5	16	23.1	26.0
CJSMBJ17A	CJSMBJ17CA	B17A XX	B17CA XX	18.90	20.90	1	5	17	21.8	27.6
CJSMBJ18A	CJSMBJ18CA	B18A XX	B18CA XX	20.00	22.10	1	5	18	20.6	29.2
CJSMBJ20A	CJSMBJ20CA	B20A XX	B20CA XX	22.20	24.50	1	5	20	18.6	32.4
CJSMBJ22A	CJSMBJ22CA	B22A XX	B22CA XX	24.40	26.90	1	5	22	16.9	35.5
CJSMBJ24A	CJSMBJ24CA	B24A XX	B24CA XX	26.70	29.50	1	5	24	15.5	38.9
CJSMBJ26A	CJSMBJ26CA	B26A XX	B26CA XX	28.90	31.90	1	5	26	14.3	42.1
CJSMBJ28A	CJSMBJ28CA	B28A XX	B28CA XX	31.10	34.40	1	5	28	13.3	45.4
CJSMBJ30A	CJSMBJ30CA	B30A XX	B30CA XX	33.30	36.80	1	5	30	12.4	48.4
CJSMBJ33A	CJSMBJ33CA	B33A XX	B33CA XX	36.70	40.60	1	5	33	11.3	53.3
CJSMBJ36A	CJSMBJ36CA	B36A XX	B36CA XX	40.00	44.20	1	5	36	10.4	58.1
CJSMBJ40A	CJSMBJ40CA	B40A XX	B40CA XX	44.40	49.10	1	5	40	9.3	64.5
CJSMBJ43A	CJSMBJ43CA	B43A XX	B43CA XX	47.80	52.80	1	5	43	8.7	69.4
CJSMBJ45A	CJSMBJ45CA	B45A XX	B45CA XX	50.00	55.30	1	5	45	8.3	72.7
CJSMBJ48A	CJSMBJ48CA	B48A XX	B48CA XX	53.30	58.90	1	5	50.5	7.8	77.4
CJSMBJ51A	CJSMBJ51CA	B51A XX	B51CA XX	56.70	62.70	1	5	53.7	7.3	82.4

Electrical Characteristics ($T_A=25^{\circ}\text{C}$ unless otherwise noted)

Part Number		Device Marking Code		Breakdown Voltage VBR@IT		Test Current	Max Reverse Leakage @VRWM	Reverse Standoff Voltage	Max Peak Pulse Current	Max Clamping Voltage @Ipp
UNI	BI	UNI	BI	Min.(V)	Max.(V)	IT(mA)	IR (uA)	V _{RWM} (V)	IPP(A)	V _c (V)
CJSMBJ54A	CJSMBJ54CA	B54A XX	B54CA XX	60.00	66.30	1	5	56.8	6.9	87.1
CJSMBJ58A	CJSMBJ58CA	B58A XX	B58CA XX	64.40	71.20	1	5	61	6.5	93.6
CJSMBJ60A	CJSMBJ60CA	B60A XX	B60CA XX	66.70	73.70	1	5	63.2	6.2	96.8
CJSMBJ64A	CJSMBJ64CA	B64A XX	B64CA XX	71.10	78.60	1	5	67.4	5.9	103.0
CJSMBJ70A	CJSMBJ70CA	B70A XX	B70CA XX	77.80	86.00	1	5	74.2	5.3	113.0
CJSMBJ75A	CJSMBJ75CA	B75A XX	B75CA XX	83.30	92.10	1	5	79.5	5.0	121.0
CJSMBJ78A	CJSMBJ78CA	B78A XX	B78CA XX	86.70	95.80	1	5	82.7	4.8	126.0
CJSMBJ85A	CJSMBJ85CA	B85A XX	B85CA XX	94.40	104.00	1	5	90.1	4.4	137.0
CJSMBJ90A	CJSMBJ90CA	B90A XX	B90CA XX	100.00	111.00	1	5	95.4	4.1	146.0
CJSMBJ100A	CJSMBJ100CA	B100A XX	B100CA XX	111.00	123.00	1	5	106	3.7	162.0

Notes:

- (1) Waveform of CJSMBJ5.0A -CJSMBJ100CA are defined as per fig.3
- (2) XXX=Code

Figure 1. Peak Pulse Power Rating Curve

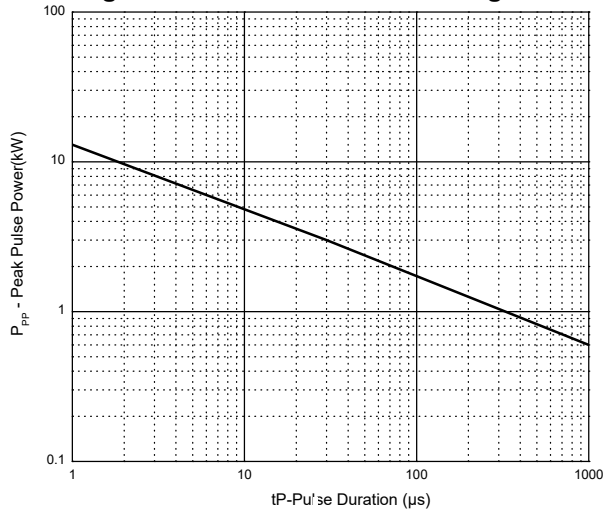

Figure 2. Pulse Derating Curve

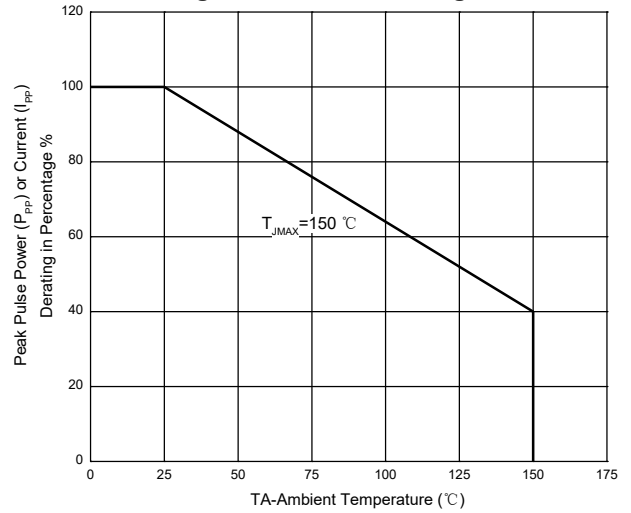

Figure 3. Pulse Waveform

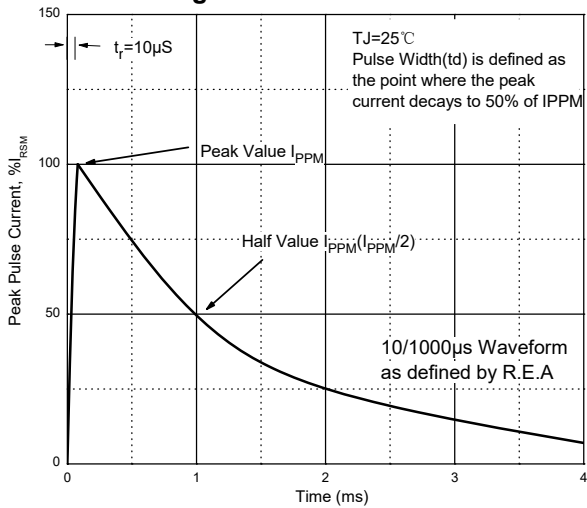

Figure 4. Typical Junction Capacitance

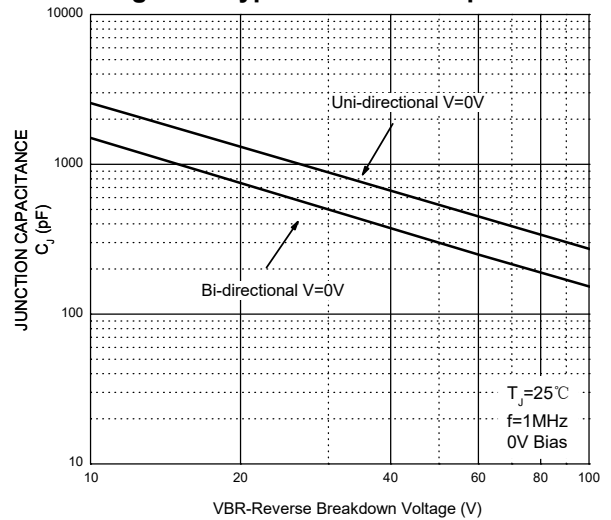

Figure 5. Steady State Power Dissipation Derating Curve

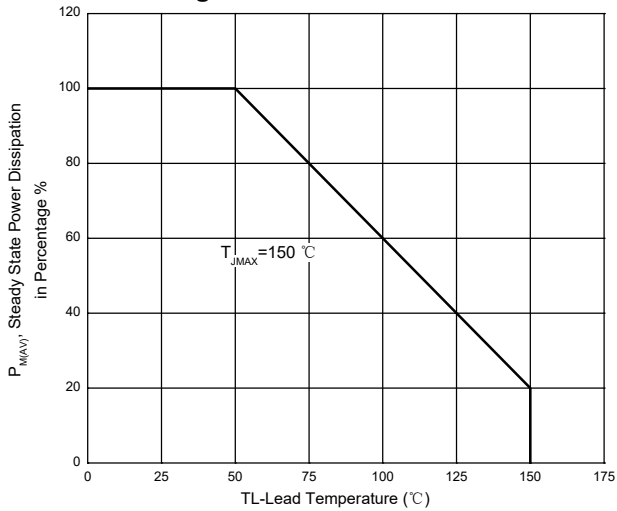
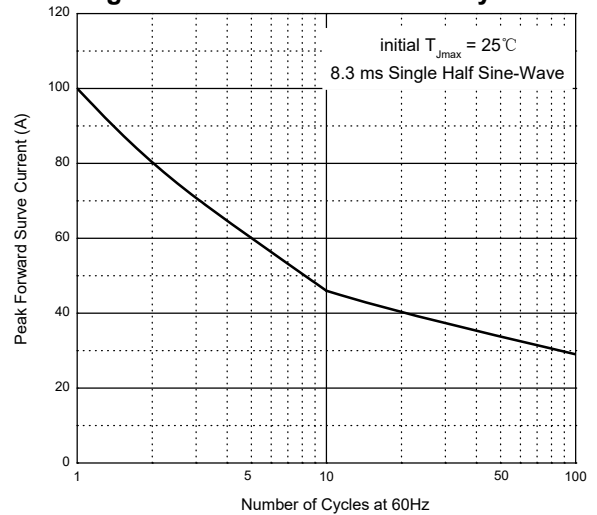
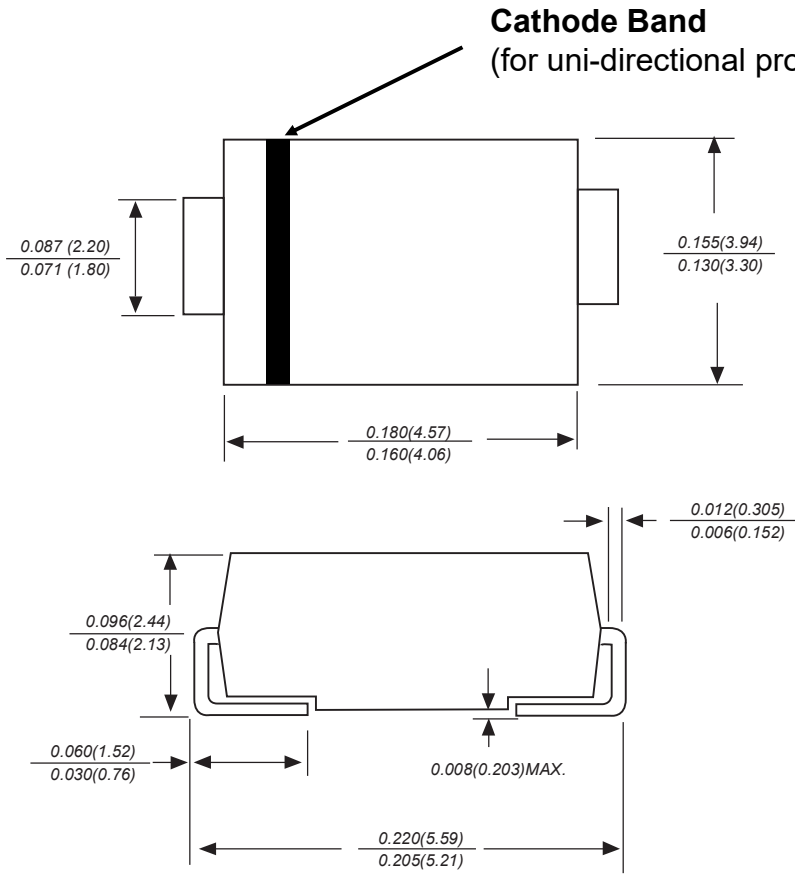

Figure 6. Maximum Non-Repetitive Forward Surge Current Uni-Directional Only



SMBG Package Outline Dimensions



Dimensions in inches and (millimeters)

SMBG Suggested Pad Layout

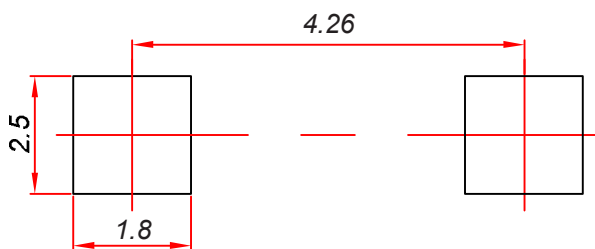

Note:

1. Controlling dimension: in millimeters.
2. General tolerance: ± 0.05 mm.
3. The pad layout is for reference purposes only.

NOTICE

JSCJ reserves the right to make modifications, enhancements, improvements, corrections or other changes without further notice to any product herein. JSCJ does not assume any liability arising out of the application or use of any product described herein.

Reel Taping Specifications For Surface Mount Devices- SMBG

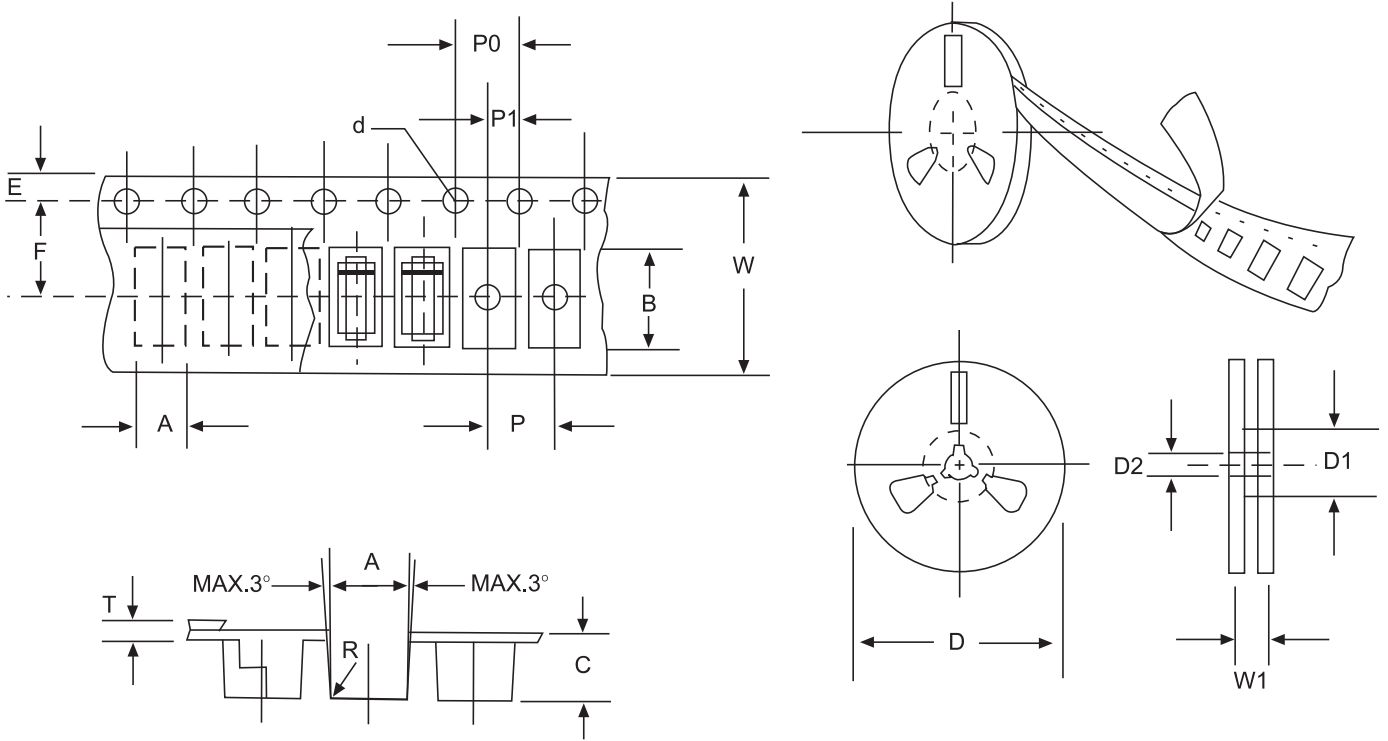

FIG: CONFIGURATION OF SURFACE MOUNTED DEVICES TAPING

ITEM	SYMBOL	SMBG mm(inch)
Carrier width	A	4.09±0.1(0.161±0.004)
Carrier length	B	5.82±0.1(0.229±0.004)
Carrier depth	C	2.50±0.1(0.100±0.004)
Sprocket hole	d	1.55±0.05(0.061±0.002)
Reel outside diameter	D	330±2.0(13±0.079)
Reel inner diameter	D1	75±1.0(2.95±0.039)
Feed hole diameter	D2	13±0.5(0.512±0.020)
Sprocket hole position	E	1.75±0.1(0.069±0.004)
Punch hole position	F	5.65±0.05(0.222±0.002)
Punch hole pitch	P	8.0±0.1(0.315±0.004)
Sprocket hole pitch	P0	4.0±0.1(0.157±0.004)
Embossment center	P1	2.0±0.1(0.079±0.004)
Total tape thickness	T	0.32±0.1(0.013±0.004)
Tape width	W	12.0±0.2(0.472±0.008)
Reel width	W1	16.8±2.0(0.661±0.079)

NOTE: Devices are packed in accordance with EIA standard RS-481-A and specification given above.