

超低阻值厚膜片式固定電阻器

LOW-OHMIC THICK FILM CHIP FIXED RESISTOR

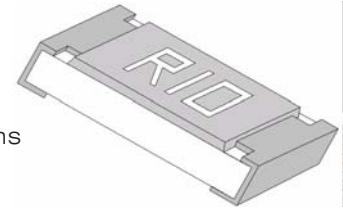

■ 超低阻值厚膜片式固定電阻器

LOW-OHMIC THICK FILM CHIP FIXED RESISTOR

● 特點 FEATURES

- * 阻值範圍: 10~1000mΩ Resistance Values from 10 to 1000m ohms
- * 最低TCR為 ±100PPM/°C Lowest TCR from ±100PPM/°C
- * 體積小、重量輕。 Miniature and light weight.
- * 適應再流焊與波峰焊。 Suit for reflow and wave flow solder.
- * 電性能穩定, 可靠性高。 Stable electrical capability, high reliability.
- * 裝配成本低, 并與自動裝貼設備匹配。 Low assembly cost, suit for automatic SMT equipment.
- * 機械强度高、高頻特性優越。 Superior mechanical and frequency characteristics.
- * 符合ROHS指令要求 According with RoHS standard

● 品名構成 TYPE DESIGNATION

例 Example

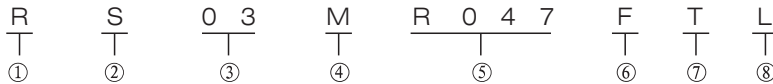

① 產品代號 Product Code
厚膜片式固定電阻器 Thick film chip fixed resistor

② 額定功率系列代號 Power Rating Series Code	
代號 Code	額定功率系列 power rating series
C	常規功率系列 normal power series
S	提升功率系列 up graded power series

③ 型號代號 Type Code	
代號 Code	型號 Type
02	0402
03	0603
05	0805
06	1206
1210	1210
10	2010
12	2512

④ 電阻溫度系數代號 Resistance Temperature Coefficient Code	
代號 Code	T.C.R
M	± 50ppm/°C ~ ± 500ppm/°C

⑤ 電阻值代號 Resistance Value Code
小數點用 R 表示。 Decimal point should be expressed by "R" 例如Example: R22=0.22Ω R10=0.10Ω R047=0.047Ω R005=0.005Ω

⑥ 電阻值誤差精度代號 Resistance Tolerance Code	
代號 Code	誤差精度 Tolerance
F	± 1%
G	± 2%
J	± 5%
K	± 10%
M	± 20%

⑦ 包裝方式代號 Packing Style Code	
代號 Code	包裝方法 Packing Style
T	編帶包裝 Tape & Reel
B	塑料盒包裝 Bulk Case
C	塑料袋散裝 Case

⑧ 無鉛化等級代號 Lead-free Level Code	
代號 Code	無鉛化等級 Lead-free Level
無表示 No Marking	端子無鉛(端子鉛含量 ≤ 100ppm) Terminal Lead-free (pb content in terminal ≤ 100ppm)
L	整體低鉛(< 1000ppm) Low Lead (pb content in resistor body < 1000ppm)
G	整體無鉛(< 100ppm) Low Lead (pb content in resistor body < 100ppm)

- * 產品標記表示方法請與廠家聯系
- * Products marked that way, please contact the manufacturer.

• 結構及規格尺寸 CONSTRUCTION AND DIMENSION

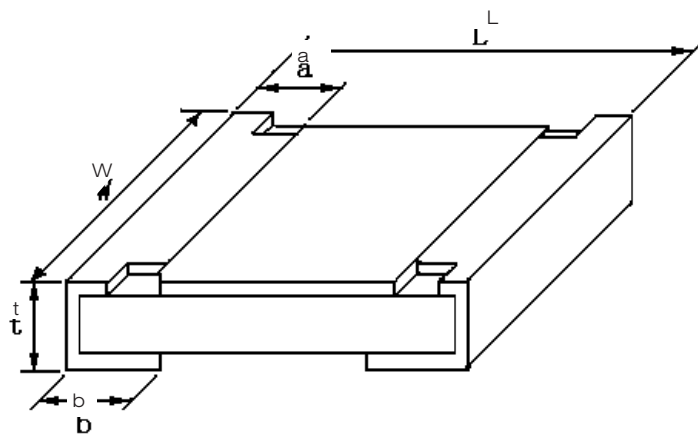
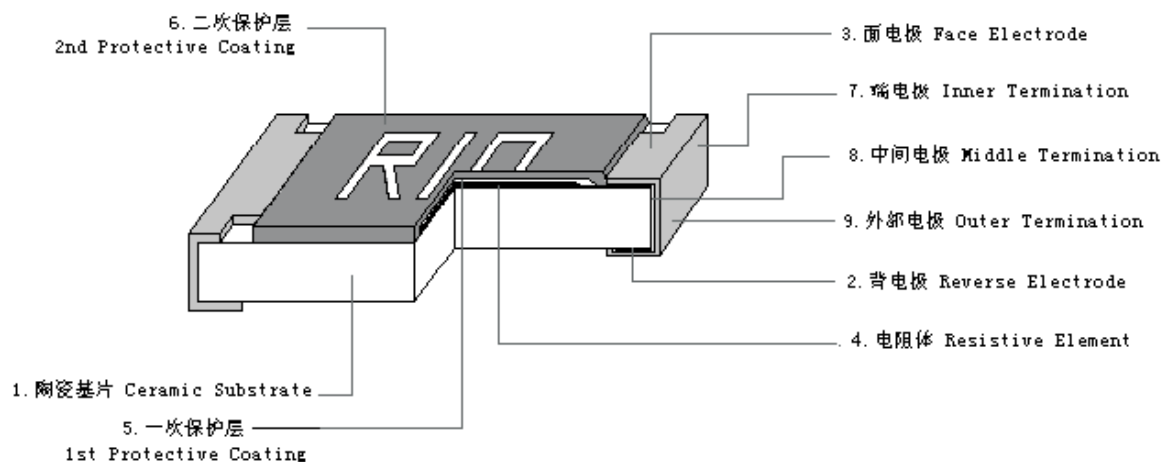

單位unit:mm

型號 TYPE	L	W	t	a	b
0402	1.00±0.10	0.50±0.10	0.30±0.10	0.20±0.10	0.25±0.10
0603	1.60±0.15	0.80±0.15	0.40±0.10	0.30±0.20	0.30±0.20
0805	2.00±0.20	1.25±0.15	0.50±0.10	0.30±0.20	0.40±0.20
1206	3.20±0.20	1.60±0.15	0.55±0.10	0.50±0.20	0.50±0.20
1210	3.20±0.20	2.50±0.20	0.55±0.10	0.50±0.20	0.50±0.20
2010	5.00±0.20	2.50±0.20	0.55±0.10	0.60±0.20	0.60±0.20
2512	6.40±0.20	3.20±0.20	0.55±0.10	0.60±0.20	0.60±0.20

● 產品外觀 APPEARANCE

- * 電阻器表面保護膜覆蓋完好且難以脫落,表面平整。

The surface of resistor is covered with Protective Coating which hard to fade, and the surface of coating should avoid unevenness.

- * 電阻器引出端電極覆蓋均勻,鍍層較難脫落,且平整、無裂痕、針孔、變色。

The terminal part is covered equable, the plating is hard to fade, and should avoid unevenness, flaw, pinhole and discoloration.

- * 電阻器芯片無裂痕、標志可辨。

With a clear mark, the resistor body is crack-free.

● 參考標準 Reference Standard

GB/T 5729-2003

GB/T 9546-1995

NSCN® | WWW.NSCN.COM.CN

總機: 025-52188228 客服: 400-888-5058

技術: 025-84712971 郵箱: TECH@NSCN.COM.CN

南京南山半導體有限公司

● 負荷下降曲線 Derating Curve

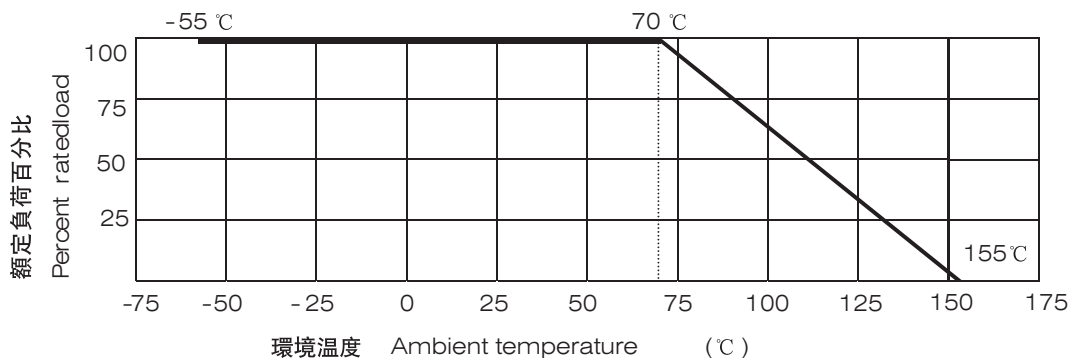

使用溫度範圍:
Operating
Temperature
Range :
-55°C ~ 155°C

- * 當電阻使用的環境溫度超過70°C時,其額定負荷(額定功率或額定電流)按上述曲線下降。

For resistors operated in ambient over 70°C, rated load (power rating or current rating) shall be derated in accordance with the above figure.

● 額定值 RATINGS

項目 Item	0402	0603	0805	1206	1210	2010	2512
額定功率 Power Rating	1/16W	1/10W	1/8W	1/4W	1/3W	3/4W	1W
最大工作電壓 Max. Working Voltage	50V	50V	150V	200V	200V	200V	200V
最大過負荷電壓 Max. Overload Voltage	100V	100V	300V	400V	400V	400V	400V
阻值範圍 Resistance Range	50mΩ~1000mΩ		20mΩ~1000mΩ		10mΩ~1000mΩ		
電阻溫度系數 Resistance Temperature Coefficient	阻值誤差精度 Resistance Tolerance		0.01Ω ≤ R < 0.1Ω: ±500ppm/°C; 0.101Ω ≤ R < 0.3Ω: ±300ppm/°C; 0.301Ω ≤ R < 1Ω: ±200ppm/°C;				
	±1% ±2% ±3%						
	阻值誤差精度 Resistance Tolerance						
±5% ±10%		0.01Ω ≤ R < 1Ω: ±500ppm/°C;					
使用溫度範圍 Operating Temperature Range	-55°C ~ +155°C						

● 低TCR系列額定值 Low TCR Series Ratings

項目 Item	0603	0805	1206	1210	2010	2512
額定功率 Power Rating	1/10W	1/8W	1/4W	1/3W	3/4W	1W
TCR (PPM/°C)	±100					
阻值範圍 Resistance Range	300mΩ~1000mΩ					
阻值誤差精度 Resistance Tolerance	±1% ±2% ±3%					
使用溫度範圍 Operating Temperature Range	-55°C ~ +155°C					

注: 額定電壓 = $\sqrt{\text{額定功率} \times \text{標稱電阻值}}$, 額定電流 = $\sqrt{\text{額定功率} / \text{標稱電阻值}}$
 Note: Rating Voltage $V = \sqrt{\text{Power Rating} \times \text{Resistance Value}}$,
 Rating Current $I = \sqrt{\text{Power Rating} / \text{Resistance Value}}$

● 特性 CHARACTERISTICS

項目 Item	標準 Specifications	測試方法(GB/T 5729-2003) Test Methods (GB/T 5729-2003)
端頭強度 Bending Strength	無可見損傷 No mechanical damage $\Delta R \leq \pm (2.0\%R + 0.005\Omega)$	彎曲距離(Bending Distance): 2010、2512: 2mm; 0402、0603、0805: 5mm 1206、1210: 4mm; 保持時間: 60s ± 5s, 然後測試阻值。 Duration: 60s ± 5s, then check the resistance.
電阻溫度系數 T.C.R	在規定值內 within specified T.C.R	測定範圍: -55°C ~ +125°C Measure between -55°C ~ +125°C
溫度循環 Temperature Cycling	無可見損傷 No mechanical damage $\Delta R \leq \pm (2.0\%R + 0.005\Omega)$	-55°C (30分鐘) ~ 常溫 (2分鐘~3分鐘) ~ 155°C (30分鐘) 5個循環 -55°C (30min) ~ normal temperature (2min~3min) ~ 155°C (30min) 5 cycles
短時間過負載 Short Time Overload	無可見損傷 No mechanical damage $\Delta R \leq \pm (2.0\%R + 0.005\Omega)$	2.5倍額定電壓或最大過負荷電壓(取最小者) 保持5秒 2.5 × Rated voltage or Max. Overload Voltage whichever is lower for 5 seconds
穩態濕熱 Steady state humidity	無可見損傷 No mechanical damage $\Delta R \leq \pm (3.0\%R + 0.005\Omega)$	40°C ± 2°C 90%~95%RH 1000小時 40°C ± 2°C 90%~95%RH 1000h

超低阻值厚膜片式固定電阻器

LOW-OHMIC THICK FILM CHIP FIXED RESISTOR

續上表

項目 Item	標準 Specifications	測試方法 (GB/T 5729-2003) Test Methods (GB/T 5729-2003)
70°C 耐久性 Load Life	無可見損傷 No mechanical damage $\Delta R \leq \pm (3.0\%R + 0.005\Omega)$	70°C ± 2°C, 1000小時, 額定電壓或最大工作電壓兩者中的較小值, 1.5小時/斷0.5小時 70°C ± 2°C, 1000h, Rated Voltage or Max. Working Voltage, whichever is lower. 1.5h on/0.5h off
上限類別溫度耐久性 Endurance at upper temperature	無可見損傷 No mechanical damage $\Delta R \leq \pm (3.0\%R + 0.005\Omega)$	155°C ± 2°C 1000h
耐溶劑性 Resistance to Solvent	無可見損傷 No mechanical damage $\Delta R \leq \pm (2.0\%R + 0.005\Omega)$	浸入三氯乙烯 10h ± 1h Dip in chloroethylene for 10h ± 1h.
絕緣電阻 Insulation Resistance	1000MΩ Min	在電極與基片間施加100V直流電壓, 保持1分鐘, 然後測絕緣電阻值。 Apply DC 100V between substrate and termination for 1 minute, then check insulation resistance.
耐焊接熱 Resistance to Soldering Heat	無可見損傷 No mechanical damage $\Delta R \leq \pm (2.0\%R + 0.005\Omega)$	270°C ± 5°C 10s ± 1s
可焊性 Solderability	可焊面積 ≥ 95% 95% Cover Min	240°C ± 5°C 2s ± 0.5s
附着力 Adhesion	外觀無可見損傷 No mechanical damage	施加力5N 10s ± 1s Applying 5N 10s ± 1s

NSCN® | WWW.NSCN.COM.CN

總機: 025-52188228 客服: 400-888-5058

技術: 025-84712971 郵箱: TECH@NSCN.COM.CN

南京南山半導體有限公司

● 包裝 PACKAGING

* 編帶包裝 Tape and reel

紙帶編帶 Paper taping

0603、0805、1206、1210;

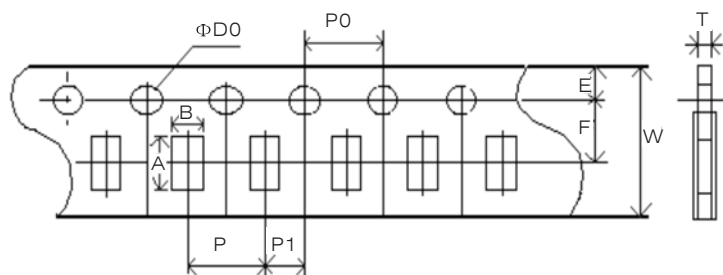

單位 Unit:mm

型號 TYPE	A	B	W	F	E
0402	1.20±0.1	0.7±0.1	8.0±0.20	3.5±0.05	1.75±0.1
0603	1.85±0.1	1.10±0.1	8.0±0.20	3.5±0.05	1.75±0.1
0805	2.35±0.1	1.65±0.1	8.0±0.20	3.5±0.05	1.75±0.1
1206	3.50±0.2	1.90±0.2	8.0±0.20	3.5±0.05	1.75±0.1
1210	3.50±0.2	2.80±0.2	8.0±0.20	3.5±0.05	1.75±0.1

單位 Unit:mm

型號 TYPE	P	P0	P1	ΦD0	T
0402	2.0±0.05	4.0±0.1	2.0±0.05	1.5±0.1	0.42±0.05
0603	4.0±0.1	4.0±0.1	2.0±0.05	1.5±0.1	0.60±0.1
0805	4.0±0.1	4.0±0.1	2.0±0.05	1.5±0.1	0.75±0.1
1206	4.0±0.1	4.0±0.1	2.0±0.05	1.5±0.1	0.75±0.1
1210	4.0±0.1	4.0±0.1	2.0±0.05	1.5±0.1	0.75±0.1

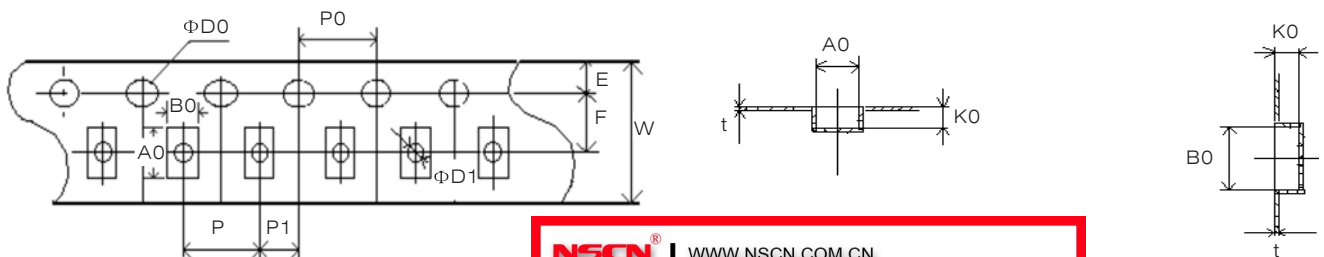
塑料帶編帶 Embossed tapping

NSCN® | WWW.NSCN.COM.CN

 总机: 025-52188228 客服: 400-888-5058
 技术: 025-84712971 邮箱: TECH@NSCN.COM.CN

南京南山半导体有限公司

單位 Unit:mm

型號 TYPE	A0	B0	W	F	E	t
2010	5.45±0.10	2.77±0.10	12.00±0.10	5.50±0.10	1.75±0.10	0.25±0.05
2512	6.73±0.10	3.40±0.10	12.00±0.10	5.50±0.10	1.75±0.10	0.25±0.05

單位 Unit:mm

型號 TYPE	P	P0	P1	ΦD0	ΦD1	K0
2010	4.00±0.10	4.00±0.10	2.00±0.05	1.50+0.10/-0	1.50±0.10	0.84±0.10
2512	4.00±0.10	4.00±0.10	2.00±0.05	1.50+0.10/-0	1.50±0.10	0.81±0.10

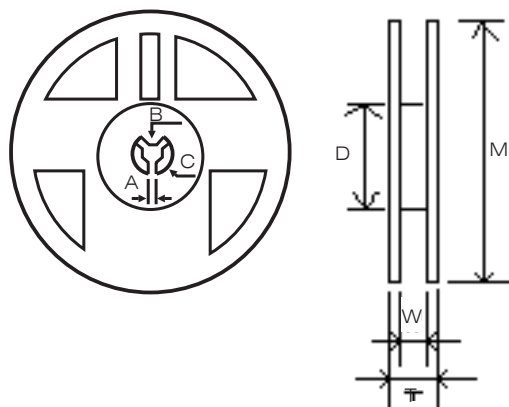
卷盤 Reel

超低阻值厚膜片式固定電阻器

LOW-OHMIC THICK FILM CHIP FIXED RESISTOR

單位 Unit:mm

型號 TYPE	M	W	T	A	B	C	D
0402	178 ±2.0	9.5 ±1.0	12.5 ±1.5	2.0 ±0.5	13.0 ±0.5	21.0 ±0.5	58.0 ±2.0
0603							
0805							
1206							
1210							
2010	178 ±2.0	13.0 ±0.5	15.5 ±1.5	2.0 ±0.5	13.0 ±0.5	21.0 ±0.5	57.0 ±2.0
2512							

* 塑料盒包裝Bulk case

單位unit:mm

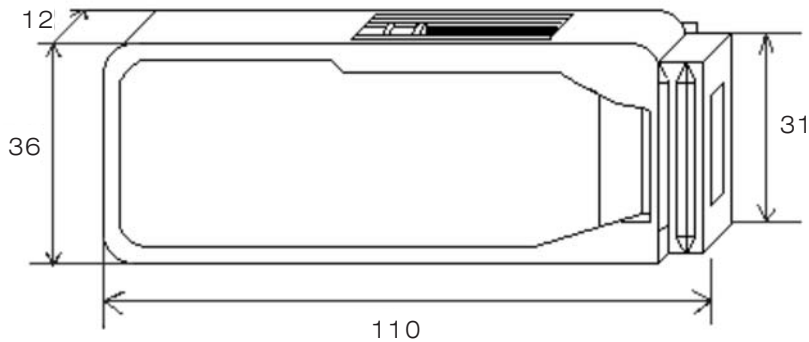

• 包裝數量 PACKAGING QUANTITY

包裝方法 Packaging style	編帶 Tape and reel			塑料盒 Bulk case						塑料袋散裝 Bulk		
	0402	0603 0805 1206 1210	2010 2512	0402	0603	0805	1206	1210 2010	2512	0402	0603 0805 1206	1210 2010 2512
數量 (PCS) Quantity	10000	5000	4000	50000	25000	10000	5000	1500	1000	≤50000	≤10000	≤4000

NSCN® | WWW.NSCN.COM.CN

总机: 025-52188228 客服: 400-888-5058

技术: 025-84712971 邮箱: TECH@NSCN.COM.CN

南京南山半导体有限公司